

Laboratory Regulation

Before operation :

1. Check the instrument list, and make sure they are okay. If there is something wrong, inform the teaching assistants (TA) or instructor.
2. No chatting, no playing in the lab. Do not treat the experimental apparatus as a toy.
3. Never wear slippers or sandals at the laboratory.
4. No food, no drinking except for water.

During operation :

1. Inform the TA or instructor when any instrument does not work properly.
2. Laboratory computer is used only for collecting and analyzing experimental data.
3. Upon finishing the experiment, check your result immediately. If the experimental error is too large, please figure out the reasons and repeat the experiment. Engineering calculator and software “MS excel” will help in analyzing data.
4. If you have problem, please think by yourself first. Do not rely on the TA too much.

After operation :

1. After the TA checks the data and gives the signature, then you can put back everything.
You will get zero point if you miss checking data with the TA.
2. Put back the instruments, and make sure the TA has checked.

Precautions :

1. The use of power :

There are two outlets, 110 V and 220 V in ac voltage, besides experimental table, please check how much voltage the instrument needs, then plug in the proper plug to avoid the damage on instruments.

Good manner in operating experimental equipment to keep it in good condition with a long life. For instance, when DC 3 V is required for experiment, make sure all control knobs are down to minima first. Then plug the power cord and turn on the power supply using the power switch or button. Wait for LED light on and then gradually increase the output voltage and current until the voltage display indicate 3V. To power off, reduce the voltage to zero, turn off the power supply and then unplug the cord.

2. The Laser safety :

LASER (Light Amplification by Stimulated Emission of Radiation) is often applied in a laboratory for its high intensity and coherent characteristics. The power of laser used in this laboratory is less than 5 mW. It is still possible to make eyes injuries since its light intensity is about several hundred times of the sun light. It should be operated carefully.

3. Connection of plug and socket

Wrong wire connections happen to the unobservant persons despite that most connectors are designed with mistake proofing. The wrong connection may influence your measurements, and sometimes damage the plug and socket. Before making electrical connection, take a close look at the pin configurations on both plug and socket and find the correct orientation for connection.

4. How should we do if the apparatus does not work?

Based on experiences, there were more than half of the cases equipment would not work because the power has not been turned on, or forgot to plug the plug of instrument into socket, then the second comes to the equipment assemble, or wiring problems. So when you find that equipment do not work, please do not look for assistant very soon, try to develop the ability of discovering the reason which makes instruments does not work (the debug ability will be helpful to their own future development) by the fore said two points, after you make sure it is not caused by the above reasons by check again, then consider it is the equipment's fault.

Absences in lab courses :

1. For either a sick leave or an official leave, the application with a proof should be filed via the school web. Once it is accepted, you need to contact TA or instructor for the schedule of completing missed experiments.
2. In case that the application cannot be filed in advance, you should talk to instructor in person within a week. Making up the missed experiment is not allowed without a fair reason.

Contents

Introduction	1
Specific heat ratio and Heat Engine	15
Magnetic force on current-carrying wires	25
Interferences and Diffraction of Light	31
Michelson Interferometry.....	41
Basic Electrical circuits	49
RLC series circuits	63
Appendices	I

Introduction

Preface :

The education in college, we not only focus on learning professional knowledge but also cultivating good experimental attitudes and habits. During the class, students can obtain the last knowledge as well as learn how to correctly and carefully use the instruments.

Pursuing the truth is the virtue of science. In the laboratory, we should realize what we are doing exactly and record all original data and that is pursuing the truth. Of course, checking whether the data are reasonable is no doubt important, but it is worthy of paying more attention to how to figure out and analyze the questions. After the experience, we should learn which factors cause the results respectively. We should know what leads to the correct answer and what leads to the wrong one. Those abilities mentioned above will benefit you in the future and that is the purpose of this class.

Take Coulomb's law as example, according to Field and Wave Electromagnetics (2/e) wrote by David K. Cheng: 「The force between two charged bodies, q_1 and q_2 , that are very small in comparison with the distance of separation, R_{12} , is proportional to the product of the charges and inversely proportional to the square of the distance, the direction of the force is along the line connecting the charges. 」 Present it mathematically:

$$\vec{F}_{12} = \hat{R}_{12} k \frac{q_1 q_2}{R_{12}^2}$$

Although it is the result from experiments, there is still a question: How small should the both bodies be to be very small in comparison with the distance of separation, R_{12} ? We should keep in mind that a point charge is an ideal assumption as well as a point mass, but in reality they are absent. We can separate two charged bodies as far as possible to fit "very small in comparison with the distance of separation" so long that the volumes are defined. However, a new question comes. Coulomb force could be too weak compared with external force from environment if the bodies are separated too far, and the data would be not accurate. Moreover, we do the experiment in the limited space. The designers and experimenters should make compromise with the current conditions. From above, inaccuracy is not avoidable.

However, it does not mean experiments are worthless due to inaccuracy. Experiments are essential to examine the truth. The wonderful theory could be abandoned without experimental support.

How can we overcome inaccuracy during the experiment? Practicing and being cautious lead to excellent consequence.

Here are some basic concepts of pursuing the truth during the experiment.

1. All data should be recorded without modification. Even the data are wrong due to clerical error, just draw two lines over them. Remember, keep all row data.
2. Record the data in the form with unit.
3. Single datum is meaningless because it could contain serious error. Therefore every experiment should be recorded five times.

Unit (SI unit) :

We should put a space between value and unit like 3 kg 、 4 K 、 5 cm ...etc.

When a name is use as unit, follow the rule below:

Newton (name) → newton (unit) → N (unit)

Hertz (name) → hertz (unit) → Hz (unit)

Ampere (name) → ampere (unit) → A (unit)

When the unit is not a name, write it in small letter:

meter = m, hour = h, second = s; but liter = liter = l = L is the only exception.

In any measurement, we could not get the exact value even with fine instruments; therefore, estimation, significant figure, and error come.

Estimation is not mentioned since we have already learnt it in high school. Here we only describe rounding, significant figure, and error.

Scientific Notation :

Scientific notation (also referred to as scientific form, standard form or standard index form) is a way of expressing numbers that are too big or too small to be conveniently written in decimal form. It is commonly used by scientists, mathematicians and engineers, in part because it can simplify certain arithmetic operations. On scientific calculators it is known as "SCI" display mode

In scientific notation all numbers are written in the form $m \times 10^n$. (m times ten raised to the power of n)

Most calculators and many computer programs present very large and very small results in scientific notation, typically invoked by a key labelled 「EXP」 or 「E」 (for exponent), depending on vendor and model.

[example 1] 1.632E-19 to 1.632×10^{-19}

[example 2] 3.00E8 to 3.00×10^8

Significant Figure :

23.76 are four significant figures. We can express the length in term of 2.376×10^{-4} km, 0.0002376 km, 0.2376 m, 23.76 cm, 237.6 mm, 237600 m, ...etc. There are all four significant figures in those mentioned above, because those “leading and trailing” 0s are not significant. Therefore, unit conversion does not affect the digit of significant figure.

If 0 does not stand for the decimal point, then boss “zero” and “nonzero” are significant figures. For example, 0.50006 and 34.209 are five significant figures. There are some rules for “0”:

1. Leading zeros are never significant.
2. Any zero contained between two non-zero number is significant.
3. Final or tailing zeros are significant only if it is after a decimal point.
4. Non-zero digits are always significant.

A. Arithmetic of Significant

(a) Addition and Subtraction Rules

If uncertainty exists in any row, then the answer is uncertain after addition and subtraction.

[example 1] $49.57 + 2903.4050 + 9.679 + 5.08 = 2967.7340 \rightarrow 2967.73$

[example 2] $123.579 - 12.41 = 111.169 \rightarrow 111.17$

(b) Division, Multiplication and Square Root Rules

The significant digit of product is determined by less significant digit of dividend, divisor, multiplicand or multiplier.

[example 1] $9500635 \times 0.58 = 5510368.30 \rightarrow 5500000 = 5.5 \times 10^6$

[example 2] $36.94 \times 28.55 = 1054.6370 \rightarrow 1055$

[example 3] $9357.98 \div 508 = 18.421 \rightarrow 18.4$

B. Banker's Rounding

Rounding financial records is extremely important. For accuracy reasons, computations are often performed with more digits than just hundredths of a dollar. The results are then rounded to hundredths of a dollar. This may all seem boring to you, but adding a penny here and there adds up real fast to large financial institutions.

1. If the part of value that will be aborted, when its first digit is equal to or greater than 6, it should round to upward.
[example] $30.29 \rightarrow 30.3$
2. If the part of value that will be aborted, when its first digit is equal to or less than 4, remove the value directly.
[example] $30.24 \rightarrow 30.2$
3. If the part of value that will be aborted is just one digit and the value is 5. Consider the previous digit was odd or even.

- (a) If there are any non-zero digits beyond the thousandths digit, then add one to the hundredths
[example] $30.256 \rightarrow 30.3$
- (b) Now we know the thousandths digit = 5 and all other digits beyond thousandths are 0. The number is exactly between two pennies. We now "round towards even," that is, if the hundredths digit is odd, then add one. Otherwise, the hundredths digit is even, so leave it alone.
[example] $30.350 \rightarrow 30.4$
[example] $30.850 \rightarrow 30.8$

Error Representation :

Error always exists, there is no measurements can get exactly accurate. In order to minimize the errors, so the best way is to know where the error from.

There are three types of errors can be deviated into system error, manual operating error, and random error:

A. Systematic Error

- (a) **Imperfect Calibration of Measurement Instruments:** It comes from improper design or aging of instruments. We should calibrate the instruments before experiment.
- (b) **Changes in Environment:** For example, thermal expansion and contraction will cause error during length measurement; therefore, an air conditioner is a solution.
- (c) **Imperfect Methods of Observation:** It comes from inaccurate theory and improper measurement setup.

B. Random Error

It is always present in a measurement. It is caused by inherently unpredictable fluctuations in the readings of a measurement apparatus or in the experimenter's interpretation of the instrumental reading. The only solution is to increase times and figure the data statistically.

Measurement is limited intrinsically; we must admit that any physics, order, and even empirical formula are not "equal" to the truth we try to express. We just describe it personally. Here we are going to discuss how to express the data statistically.

C. Manual operating Error

It is often caused by carelessness like calculation error and clerical error. The solution is doing the experiment repeatedly (In this class, 5 times are needed and it is better to do it in tern) to find out unreasonable data. Do not falsify the wrong data. Repeats are the only solution and remember do not take the data solely, because the new data does not belong to the original ones. Additionally, poor habits are also the possible reason for the artificial error.

Data Representation :

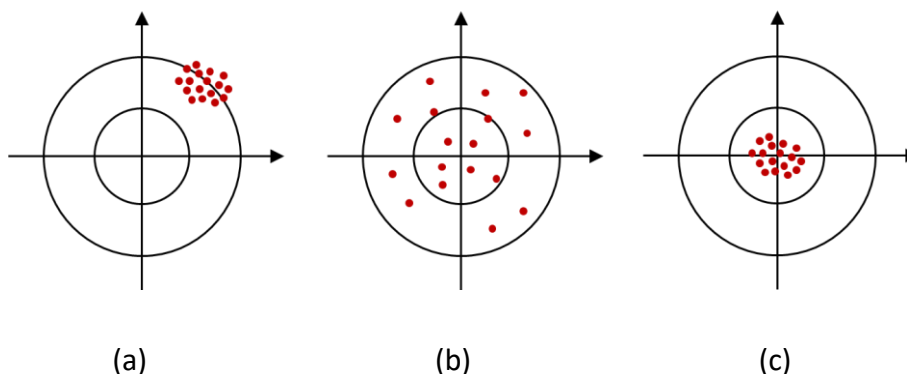

Figure 1. Precision and accuracy illustration

In order to describe precisely physical quantity measured from the experiment, quantity, precision and accuracy, and unit should be included:

- A. Quantity and unit :** Every quantity (estimation included) should be written in form of significant figure and scientific notation ($a.bc \times 10^n$ unit) except for some physically-defined values (such as : $c \sim 3.00 \times 10^8$ m/s , $e \sim 1.60 \times 10^{-19}$ Cetc) and numerical constants (such as : R , N_A etc).
- B. Precision and Accuracy :** Usually expressed in form of “ $a \pm b$ ”. Strictly speaking, precision and accuracy are different.
- (a) **Precision** – It is a measure of how well the result has been determined, without reference to its agreement with the true value, and it also reflects the random error. In figure 1(a), the data are precise and random error is small.
- (b) **Accuracy** –It is a measure of the correctness of the result and it reflects the systematical error. In figure 1(b), the data are accurate and systematical error is small.
- (c) **Precision and Accuracy** – The synthetic index is random error and systematical error. In figure 1 (c) the data are both precise and accurate. Random error and systematical error are both small.

Statistical Analysis :

Statistical analysis is often applied to data analyzing and it is a logistical and powerful instrument.

A. Mean

$$\bar{x} = \frac{x_1 + x_2 + \cdots + x_n}{n} = \sum_{i=1}^n \frac{x_i}{n}$$

To be notice, mean does not represent the real value and even not the most possible value. We can state it nothing more than “representative”.

B. Deviation

$$d_i = x_i - \bar{x}$$

C. Average deviation

$$D = \frac{\sum_{i=1}^n |d_i|}{n}$$

D. Average deviation percentage

$$\frac{D}{\bar{x}} \times 100\%$$

E. Standard deviation

$$\sigma = \sqrt{\frac{\sum_{i=1}^n d_i^2}{n-1}}$$

When number of measurements is huge (ideally $n \rightarrow \infty$), data can be described by a normal distribution. The deviation of a value can be presented in terms of numbers of average standard deviation and the percentage of data points with such value of the data set is obtained. For a normal distribution, the values less than one standard deviation from the mean account for 68.27% of the set; while two standard deviations from the mean account for 95.45%; and three standard deviations account for 99.73%. For instance, a statement of 「mean mass 127 g with standard deviation of 2 g」 means that 「about 70% of measured values are between 125 g and 129 g」.

F. Standard deviation of the mean

$$\sigma_x = \frac{\sigma}{\sqrt{n}} = \sqrt{\frac{\sum_{i=1}^n d_i^2}{n(n-1)}}$$

If we do some more measurements, the standard deviation would not change appreciably. On the other hand, the standard deviation of mean would slowly decrease we increase n . However, the factor \sqrt{n} grow rather slowly as we increase n . For example, if

we want to improve our precision by a factor of 10, that means we will have to increase n by a factor of 100. Thus, in practice, if we want to increase our precision appreciably, we will probably do better increase our technique than to rely merely on increased numbers of measurements.

G. Correlation coefficient

$$\gamma = \frac{\sum_{i=1}^n (x_i - \bar{x})(y_i - \bar{y})}{n\sigma_x\sigma_y} = \frac{\sum_{i=1}^n (x_i - \bar{x})(y_i - \bar{y})}{\sqrt{\sum_{i=1}^n (x_i - \bar{x})^2 \sum_{i=1}^n (y_i - \bar{y})^2}}$$

$\gamma = 0$	non-correlation
$0.0 < \gamma < 0.3$	low correlation
$0.3 < \gamma < 0.7$	moderate correlation
$0.7 < \gamma < 1.0$	high correlation
$\gamma = 1$	fully correlation

H. Experimental result

The data should be record in form of $\bar{x} \pm \sigma_x$ with unit.

Mean and Error Transfer :

Two or more experimental results of the arithmetic, should be consider the error transfer.

Let $x = \bar{x} \pm \sigma_x$ and $y = \bar{y} \pm \sigma_y$

A. Error Transfer of Addition and Subtraction

$$\overline{x \pm y} = \bar{x} \pm \bar{y} \quad \text{and} \quad \sigma_{x+y}^2 = \sigma_x^2 + \sigma_y^2$$

$$x \pm y = (\bar{x} \pm \bar{y}) \pm \sigma_{x+y} \quad \text{and} \quad \sigma_{x+y} = \sqrt{\sigma_x^2 + \sigma_y^2}$$

In general form :

$$\sigma_N^2 = \sum_{i=1}^n \sigma_i^2$$

B. Error Transfer of Multiplication and Division

(a) Multiplication

$$x \times y = \overline{(xy)} \pm \sigma_{xy}$$

$$\text{where } \overline{(xy)} = \bar{x} \times \bar{y} \quad \text{and} \quad \sigma_{xy} = \sqrt{\left[\left(\frac{\sigma_x}{\bar{x}}\right)^2 + \left(\frac{\sigma_y}{\bar{y}}\right)^2\right]} \times (\bar{x} \times \bar{y})$$

(b) Division

$$\frac{x}{y} = \overline{\left(\frac{x}{y}\right)} \pm \sigma_{\frac{x}{y}}$$

$$\text{where } \overline{\left(\frac{x}{y}\right)} = \frac{\bar{x}}{\bar{y}} \quad \text{and} \quad \sigma_{\frac{x}{y}} = \sqrt{\left[\left(\frac{\sigma_x}{\bar{x}}\right)^2 + \left(\frac{\sigma_y}{\bar{y}}\right)^2\right]} \times \frac{\bar{x}}{\bar{y}}$$

In general form :

$$\left(\frac{\sigma_N}{y}\right)^2 = \left(\frac{\sigma_1}{y_1}\right)^2 + \left(\frac{\sigma_2}{y_2}\right)^2 + \dots + \left(\frac{\sigma_n}{y_n}\right)^2$$

where y is the average derived and y_1, y_2, \dots, y_n are average of every element in the calculation.

C. Error Transfer of Power law

$$x^l \times y^m = (\bar{x}^l \times \bar{y}^m) \pm \sigma_{x^l y^m}$$

$$\text{where } \overline{x^l \times y^m} = (\bar{x}^l \times \bar{y}^m) \quad \text{and} \quad \left(\frac{\sigma_{x^l y^m}}{\bar{x}^l \times \bar{y}^m}\right)^2 = l^2 \left(\frac{\sigma_x}{\bar{x}}\right)^2 + m^2 \left(\frac{\sigma_y}{\bar{y}}\right)^2$$

D. Error Transfer of General Standard Deviation

Set $N = f(x, y)$ and then,

$$\sigma_N = \sqrt{\left(\frac{\partial f}{\partial x}\right)^2 \sigma_x^2 + \left(\frac{\partial f}{\partial y}\right)^2 \sigma_y^2}$$

Least Square Regression Analysis :

It is an analysis instrument in common use. By fitting the optimized regression, we are able to minimize the sum of square of vertical distance to the regression.

For n data sets:

$$(x_i, y_i), \quad i = 1, 2, 3, \dots, n$$

A. Linear regression

If the optimized regression is the form of $y = f(x) = Ax + B$, where A and B unknown, then the sum of square of vertical distance to the regression is:

$$D(A, B) = \sum_{i=1}^n [f(x_i) - y_i]^2 = \sum_{i=1}^n [Ax_i + B - y_i]^2$$

The so-called optimization is to decrease $D(A, B)$ for a minimum,

$$\frac{\partial D}{\partial A} = 0 \quad ; \quad \frac{\partial D}{\partial B} = 0$$

$$\begin{aligned} \frac{\partial D}{\partial A} &= \sum_{i=1}^n \frac{\partial}{\partial A} [Ax_i + B - y_i]^2 = \sum_{i=1}^n 2[Ax_i + B - y_i]x_i \\ &= 2 \sum_{i=1}^n [Ax_i^2 + Bx_i - x_i y_i] = 2 \left[A \sum_{i=1}^n x_i^2 + B \sum_{i=1}^n x_i - \sum_{i=1}^n x_i y_i \right] = 0 \\ \frac{\partial D}{\partial B} &= \sum_{i=1}^n \frac{\partial}{\partial B} [Ax_i + B - y_i]^2 = 2 \left[\sum_{i=1}^n Ax_i + \sum_{i=1}^n B - \sum_{i=1}^n y_i \right] \\ &= 2 \left[A \sum_{i=1}^n x_i + nB - \sum_{i=1}^n y_i \right] = 0 \end{aligned}$$

And the solutions are

$$A = \frac{n[\sum_{i=1}^n x_i y_i] - [\sum_{i=1}^n x_i] \cdot [\sum_{i=1}^n y_i]}{n[\sum_{i=1}^n x_i^2] - [\sum_{i=1}^n x_i]^2} \quad ; \quad B = \frac{[\sum_{i=1}^n y_i] - A[\sum_{i=1}^n x_i]}{n}$$

We can just input (x_i, y_i) to engineering calculator or software like MS-excel, and then A and B can be obtained.

B. Exponential regression

It describes the data in form of $y = A \times e^{Bx}$. Also, it can be applied through calculator or software.

C. Logarithmic regression

It describes the data in form of $y = A \times \ln x + B$, Also, it can be applied through calculator or software.

D. Power regression

It describes the data in form of $y = A \times x^B$, Also, it can be applied through calculator or software.

Format of a laboratory report

Cover (Title page)

Free style

Indicate the title and your name, department, class, group, and student ID number.

Introduction

State the objective of the experiment and provide the reader with background to the experiment.

Background stories, previous researches, and interesting related information

Theories

Briefly provide the concept and related theories.

Explain how you derived that hypothesis.

Methods

Document the methods, subjects, materials, and equipment you used to collect data.

Results

Present the results of the clinical studies in a clear and concise manner. Data may be offered in tables, charts, and graphs.

Graphs and figures must both be labeled with a descriptive title. Label the axes on a graph, being sure to include units of measurement.

Discussion

Interpret the results and explain how they relate to the theoretical prediction.

Compare your **experimental results** and **the theoretical prediction** and analyze how they consistent or inconsistent.

Check errors in experimental data and find out the sources of them.

Discuss any limitations or sources of error in the experiment and how they can be improved upon.

Conclusion

Summarize the main findings of the experiment and the conclusions that can be drawn

Avenue suggestions for future research

Any related application in daily life?

References

Cite all sources in the report. Name of the author, title of the article, name of the journal with volume and page numbers, and year of publication should be included.

Format of a figure

Example :

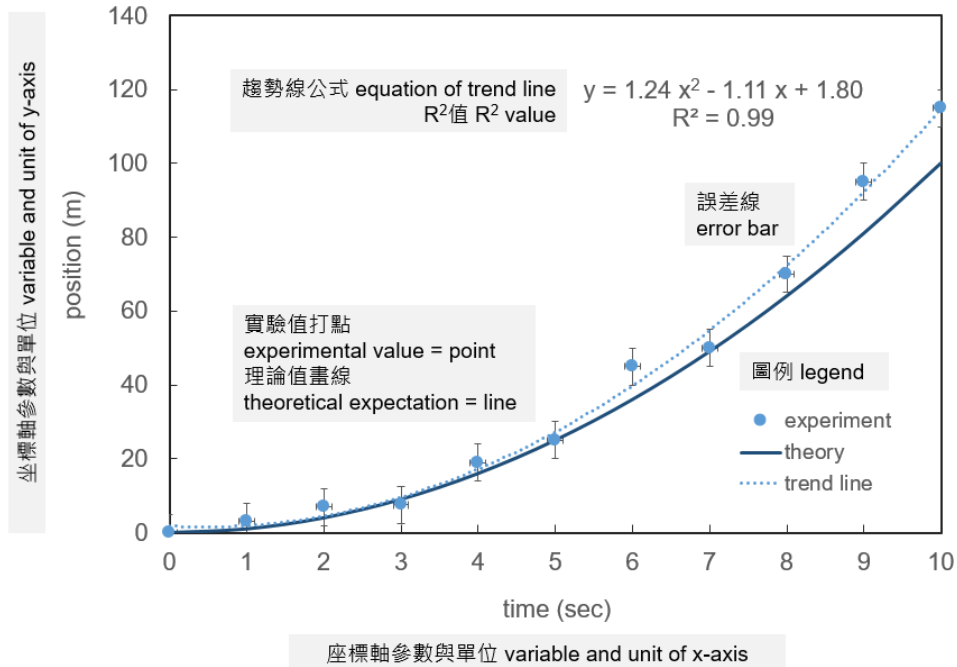

Figure 1. Plot of position of an object vs. time. Circles are experimental data and the solid line is obtained by the theory. The dashed line is the trend line. (Figure caption)

Constitutes :

- Variables with units of axes
- data : points (x_i, y_i)
- error of each experimental value : error bar
- theory : a solid line or curve
- trend line : a dashed line or curve
- legend : indication of the meaning of each data set
- Equation of trend line $y(x)$ and R^2 value (a measure about the goodness of fit of $y(x)$)

$$R^2 = 1 - \frac{\sum(y_i - y(x_i))^2}{\sum(y_i - \bar{y})^2} \quad \text{and} \quad \bar{y} = \frac{\sum y_i}{n} \quad n: \text{number of data points}$$

- Figure caption : figure number and description

The rules to calculate significant figures for arithmetic

Significant figures express the uncertainty of a measurement or number. All measurements have some degree of uncertainty in their value. This is inherent in measuring tools and variations between people taking measurements. For instance, using a ruler to measure the length of a pencil. The graduation of the ruler is 1 mm. The measured value is 150.51 mm where 150.5 are precise and 「1」 on the right of 「5」 is estimated. 150.51 mm has five significant figures. For another example, using two electronic scales to measure the same weight. 2.20 g and 2.1745 g are obtained, respectively. Hence, we know that the accuracy of these two scales are ± 0.01 g and ± 0.0001 g, respectively. Notice that 0 in 「2.20 g」 should not be omitted to indicate ± 0.01 g in accuracy. Upon measurement, your significant figures should include all measurable digits (the digits that correspond to the marks on the ruler) as well as one estimated position beyond the smallest measurable digit.

It may be easy to handle to use scientific notation for the measured value in calculations. In scientific notation all numbers are written in the form $m \times 10^n$. (m times ten raised to the power of n). For instances,

$$0.3456 = 3.456 \times 10^{-1}$$

$$4567.8 = 4.5678 \times 10^3$$

where the **bold numbers** are precise and the grey number with underline are estimated

In the experiment, some values – like averages or totals – are not measured directly. Rather, they are calculated from measured values. In a calculation, the uncertainty of the result is determined by the uncertainty of the measurements. In this case, the calculated values must also follow the rules of significant figures, and the number of significant figures in the calculated value is dependent on the values used in calculation.

Addition/Subtraction :

- Numbers of same significant figures (straightforward)

$$3.456 \times 10^{-1} + 1.001 \times 10^{-1} = 4.457 \times 10^{-1}$$

All numbers have four significant figures.

- Numbers of different significant figures

$$3.45\bar{6} \times 10^{-1} + 1.\bar{1} \times 10^{-1} = 4.\bar{5} \times 10^{-1}$$

The number of decimal places in the result should equal the smallest number of decimal places in any term in the sum.

- a **carry** (a digit that is transferred from one column of digits to another column of more significant digits)

$$3.45\bar{6} \times 10^{-1} + 8.00\bar{1} \times 10^{-1} = 11.45\bar{7} \times 10^{-1}$$

Both $11.4\bar{6} \times 10^{-1}$ (four significant figures) and $11.45\bar{7} \times 10^{-1}$ (five significant figures) are accepted.

Multiplication/Division :

- Numbers of same significant figures (straightforward)

$$(3.45\bar{6} \times 10^{-1}) \times (1.00\bar{1} \times 10^{-1}) = 3.45\bar{9} \times 10^{-2}$$

All numbers have four significant figures

- Numbers of different significant figure

$$(1.00\bar{1} \times 10^7) \times (1.\bar{1} \times 10^{-1}) = 1.\bar{1} \times 10^6$$

The number of significant figures is the same as the number of significant figures in the quantity having the lowest number of significant figures.

- a **carry** (a digit that is transferred from one column of digits to another column of more significant digits)

$$(5.00\bar{1} \times 10^2) \times (5.00\bar{1} \times 10^7) = (25.01\bar{0} \times 10^9)$$

Both $25.0\bar{1} \times 10^9$ (four significant figures) and $25.01\bar{0} \times 10^9$ (five significant figures) are accepted.

Specific Heat Ratio of a Gas and Heat Engine

Objective :

A. Specific heat ratio of a gas

Using Rüchardt Method to measure the ratio of specific heat of gas.

B. Heat Engine

Verify the thermal cycle curve (isothermal, isobaric, expansion, and compression) and obtain an actual PV curve using a real heat engine.

Apparatus :

Gas law apparatus(TD-8572), dual pressure sensor(blue 、PS-2181), transparent tubing with Quick-Connect Fittings, metal can, weight, thermometer(Stainless Steel), absolute pressure /temperature sensors(blue 、PS-2146), Air-Link(white 、PS-3200), computer (software Capstone).

Principle :

A. Absorption and liberation of heat at system

In this experiment, the system is the gas, when the environmental temperature greater than system temperature ($T_{env} > T_{sys}$), the system absorbed heat from outside. At this time, we define the heat dQ is positive that the system absorbed; on the other hand, when $T_{env} < T_{sys}$, the heat flow into surrounding from the system, it means exothermal, now dQ is negative. As shown in figure 1

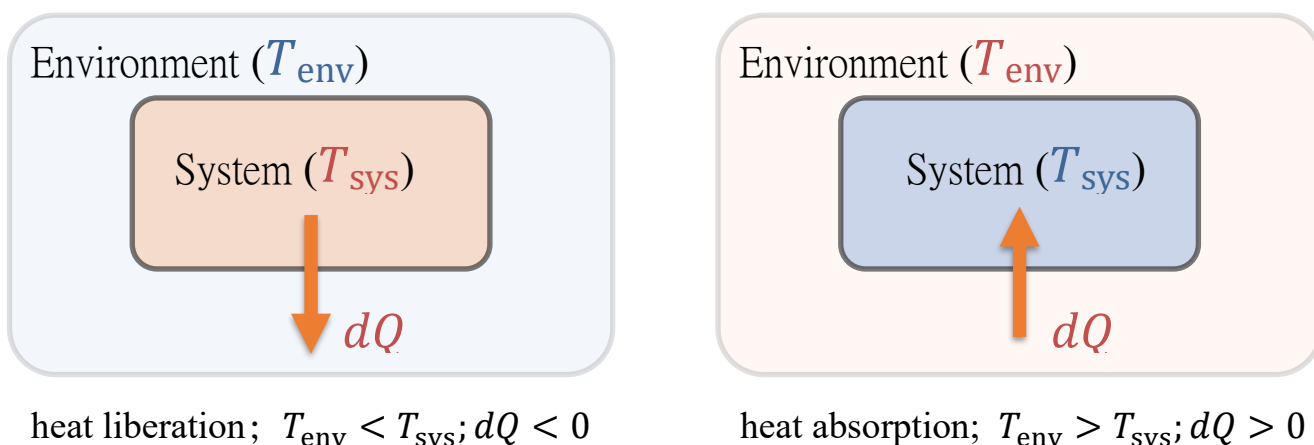

Figure 1. Schematics of heat liberation (L) and absorption (R) of system.

● The first Law of thermodynamics $dE_{int} = dQ - dW = dQ - PdV$

E_{int} is the internal energy at the system, Q is the heat, and W is the work done on the surroundings by the system. For the ideal gas, its internal energy is just related to temperature, that is $dE_{int} = dE_{int}(T)$.

- **Adiabatic process for ideal gas**

In “adiabatic process”, work exerted on the air will be totally converted into the internal energy, and hence the pressure and temperature will rise; on the other hand, when the air expands, it does work on the surroundings. Therefore, the internal energy of air decreases and the pressure and temperature decrease.

- **Isothermal process for ideal gas**

In the “isothermal process”, the internal energy at the system isn't changed; we would know that $dQ = dW$ from the first Law of thermodynamics. When the air is compressed, the surroundings do work on the air. Therefore, the pressure rises, and the system has to transfer energy out to the surroundings to maintain the same temperature ($dQ < 0$). On the contrary, when the system (air) expands, it does work on the surroundings. The pressure decreases and hence, the system needs to absorb heat ($dQ > 0$) to maintain the temperature.

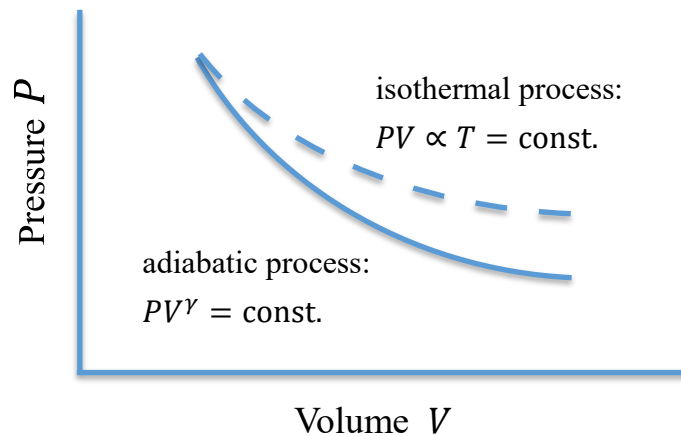

. Figure 2. Pressure - Volume curve for adiabatic and isothermal processes.

From 1st law of thermodynamics, $dE_{int} = dQ - dW = dQ - PdV$, P changes more rapidly in adiabatic process than in isothermal process. i.e. P - V curve is steeper in adiabatic process (as shown in the following figure).

Consider an ideal gas, from 1st law of thermodynamics, we know the heat dQ flow into the gas, the difference of internal energy dE_{int} ; and the work done on the surroundings by the system is PdV . It would be written:

$$dQ = dE_{int} + PdV \quad (1)$$

B. Molar specific heat

If the volume of the gas remains a constant, then the heat to rise one degree per mole gas is called “molar specific heat at constant volume” – C_V . From equation (1), we have

$$C_V = \left(\frac{dQ}{dT}\right)_V = \left(\frac{\partial E_{int}}{\partial T}\right)_V = \frac{dE_{int}}{dT} \quad (2)$$

By equations (1) and (2) could get

$$dQ = C_V dT + PdV \quad (3)$$

From ideal gas equation $PV = nRT$. Let $n=1$ and do derivative on both sides, we can get

$$dV + VdP = RdT \quad (4)$$

By equation (3) and (4) could get

$$\begin{aligned} dQ &= C_V dT + RdT - VdP \\ &= (C_V + R)dT - VdP \end{aligned} \quad (5)$$

If the pressure of the gas remains a constant, then the heat to rise one degree per mole gas is called “molar specific heat at constant pressure” $-C_p$. Into equation (5), that $dP=0$

$$\begin{aligned} dQ &= (C_V + R)dT \\ C_p &= \left. \frac{\partial Q}{\partial T} \right|_P = C_V + R \end{aligned} \quad (6)$$

C. Ratio of specific Heat γ

The ratio of molar specific heat γ is defined as the ratio of molar specific heat at constant pressure $-C_p$ to molar specific heat at constant volume $-C_V$, that is measurement.

$$\gamma = \frac{C_p}{C_V} = \frac{C_V + R}{C_V} \quad (7)$$

It can also be calculated by statistical mechanics. In statistical mechanics, each degree of freedom contributes, on average, $\frac{1}{2}RT$ of energy per molecule. In our life, most gases are diatomic gases, which the molecules have the shape of a dumbbell. In this model, there are five degrees of freedom; three are related to the translational motion and two related to rotational motion; the vibrational motion along the molecule axis is neglected in this case.

Therefore, one mole of air has $\frac{5}{2}RT$ of internal energy, i.e. $C_V = \frac{5}{2}R$, and $C_p = C_V + R = \frac{7}{2}R$. Hence the theoretical value γ is 1.40.

$$\gamma \equiv \frac{C_p}{C_V} = \frac{C_V + R}{C_V} = \frac{(5/2)R + R}{(5/2)R} = 7/5 = 1.4 \quad (8)$$

D. Adiabatic gas equation

Air is a very poor heat conductor. When air is either compressed or expanded suddenly, every portion of air could not exchange heat in time and no heat flow in or out of the system at that instant. It can be regarded as a adiabatic process and the change of heat is zero ($dQ = 0$). According the first law of thermodynamics,

$$dE_{\text{int}} = dQ^=0 - dW = -PdV \quad (9)$$

Substitute equation (9) into equation (2)

$$C_V dT + P dV = 0 \quad (10)$$

By ideal gas formula ($n = 1$)

$$PV = RT \Rightarrow P = \frac{RT}{V} \quad (11)$$

Substitute equation (11) into equation (10)

$$\begin{aligned} C_V dT + \frac{RT}{V} dV &= 0 \\ \Rightarrow \frac{dT}{T} + \frac{R}{C_V} \frac{dV}{V} &= 0 \end{aligned} \quad (12)$$

Integrating equation (12), we can get

$$\begin{aligned} \ln T + \ln V^{R/C_V} &= \text{const.} \\ \Rightarrow TV^{R/C_V} &= \text{const.} \end{aligned} \quad (13)$$

By ideal gas formula ($n = 1$) again,

$$PV = RT \Rightarrow T = \frac{P}{R} V \quad (14)$$

Substitute equation (14) into equation (13)

$$\begin{aligned} \frac{P}{R} \cdot V \cdot V^{R/C_V} &= \frac{P}{R} \cdot V^{(R/C_V)+1} = \text{const.} \\ \Rightarrow PV^{(R+C_V)/C_V} &= \text{const.} \end{aligned} \quad (15)$$

then we can get

$$\begin{aligned} PV^{C_p/C_V} &= \text{const.} \\ PV^\gamma &= \text{const.} \end{aligned} \quad (16)$$

As show in figure 3, press the piston with appropriate power quickly, the piston will move downward x and receives the upward pressure. The piston will upward movement because of received the upward pressure, gas pressure shakes with time. This process without heat enters in or flows out, so the process is adiabatic process. And the gas in the apparatus of law-atmosphere is satisfied adiabatic process gas equation $PV^\gamma = \text{const.}$

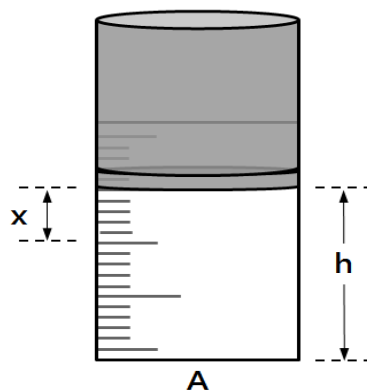

Figure 3. Schematic of air cylinder.

The Rüchardt experimental technique may obtain the air ratio of specific heats is, the inferential reasoning process is as follows. Do the differential operation on the equation (16).

$$V^\gamma dP + \gamma PV^{\gamma-1} = 0$$

$$\Rightarrow dP = -\frac{\gamma P}{V} dV \quad (17)$$

Substitute $dV = xA$ into equation (17), we can get

$$dP = -\frac{\gamma P}{V} dV = -\frac{\gamma P}{V} xA \quad (18)$$

The net force F on piston can be expressed by pressure dP and area A ,

$$F = (dP)A$$

$$= -\frac{\gamma PAx}{V} A = -\frac{\gamma PA^2}{V} x \quad (19)$$

The piston oscillates up and down caused by the force. The net force and movement of piston satisfy simple harmonic case $F = -kx$, so

$$F = -\frac{\gamma PA^2}{V} x$$

$$\Rightarrow k = \frac{\gamma PA^2}{V} \quad (20)$$

The oscillation period of piston is (here, m is the mass of piston.)

$$T = 2\pi \sqrt{\frac{m}{k}} = 2\pi \sqrt{\frac{mV}{\gamma PA^2}} \quad (21)$$

Item :

A. Specific Heats Ratio of a Gas γ

Gas law apparatus (TD-8572) is shown in figure 4. The piston cross-sectional area A , the mass of piston m are displayed on the front panel of the apparatus. Here, P_0 is atmosphere pressure.

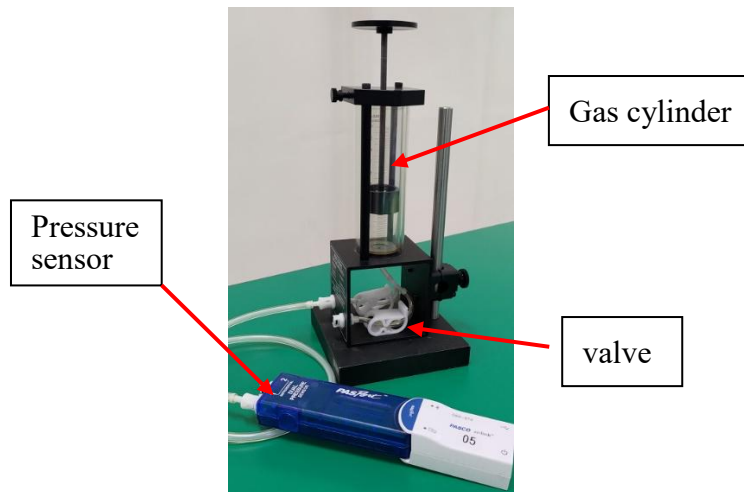

Figure 4. Gas law apparatus.

1. Pull the piston up to a suitable height h , close the valve that is not connects with the pressure sensor.
2. The total gas pressure P is sum of an atmosphere pressure and the pressure of piston, therefore, $P = P_0 + \frac{mg}{A}$.
3. The total air volume V is sum of the air volume of piston (underneath scale zero) Ah , the air volume in switch valve rubber pipe (underneath piston) and connection low pressure sensing rubber pipe air volume V' , therefore, $V = V' + Ah$.
4. Based on equation (21), the relation between the height h and the square of the oscillation period of piston T^2 is as follows.

$$T = 2\pi \sqrt{\frac{m}{k}} = 2\pi \sqrt{\frac{mV}{\gamma p A^2}}$$

$$\Rightarrow V = \frac{\gamma P A^2}{4\pi^2 m} T^2 = V' + Ah$$

$$\Rightarrow \frac{\gamma P A}{4\pi^2 m} T^2 = h + \frac{V'}{A}$$

5. Plot the diagram of T^2 versus h . Using the slope of the linear fit and other known physical quantities, we can get the molar specific heat ratio of the air, γ .

$$\text{slope} = \frac{4\pi^2 m}{\gamma P A}$$

$$\gamma = \frac{4\pi^2 m}{P A (\text{slope})}$$

Procedure A :

1. Open both valves located at the bottom of gas law apparatus and raise the piston to an appropriate altitude and then size the piston by one hand. Close the valve connected with the low-pressure sensor by using another hand. Loosen the piston and record the altitude of the piston h .
2. Open software capstone and set all parameters in on the entry screen based on the operation manual. Press the start button to start acquiring data, meanwhile press the piston with appropriate power quickly.
3. When the 『 Pressure-Time 』 diagram don't change, no oscillation, press the stop button to stop acquiring data.
4. Record five periods time, then calculate the period T .
5. Change altitude of piston and repeat steps.
6. Plot the diagram of 『 T^2 vs. h 』, and find the slope by linear regression analysis.
7. Calculate the ratio of molar specific heat of air and percentage of error.

Item :

B. Heat Engine

Gases can exchange energy with the environment by doing work. The work process that the volume of the gas is changed but temperature is kept the same is called an isothermal process. On the other hand, the work process that the volume of the gas is changed but pressure is kept the same is called an isobaric process. In this experiment, the relation between the gravitational potential energy (mgy) due the vertical displacement (y) of a weight and the net thermodynamic work (PV) of the gas during thermal cycling is verified by operating a real heat engine.

The heat engine consists of a hollow cylinder with a low friction graphite piston that can move along the axis of the cylinder. The piston has a platform attached to it for lifting a mass. A metal can sealed with a rubber stopper connects through flexible tubing to the heat engine. The heat engine consists of the air inside a metal cylinder. The air expands when the cylinder is put into hot water. The expanding air pushes on a piston and does work by lifting a mass. The heat engine cycle is then completed when the cylinder is put into cold water, and the air pressure and volume return to the starting values. A schematic diagram of the heat engine is shown in figure 5.

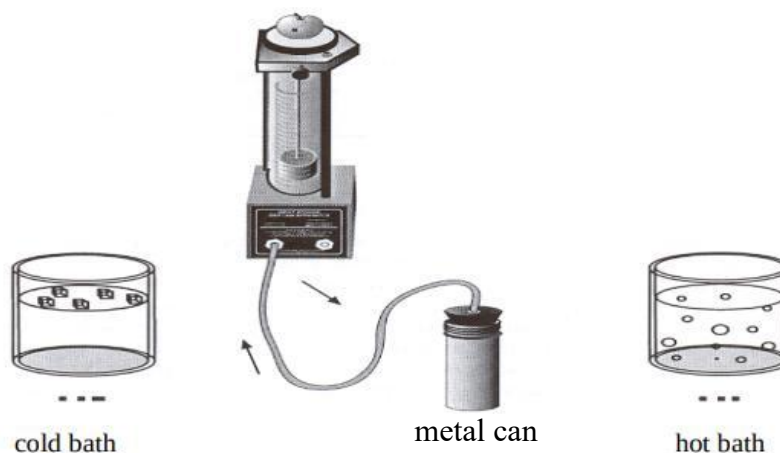

Figure 5. Schematic of heat engine.

Procedure B :

1. Verifying the thermal cycle curve via a real heat engine

By a real heat engine to verify the thermal cycle curve (isothermal, isobaric, expansion, and compression). The ideal thermal cycle curve is plotted in figure 6. The actual operation steps is shown in figure 7. A thermometer is required to attach the wall of can to monitor the temperature of gas inside the can. Tie the thermometer on the can wall with a rubber band.

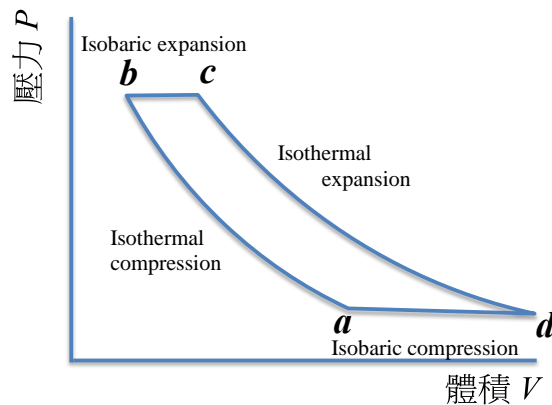

Figure 6. Schematic of the ideal thermal cycle curve.

- Isothermal compression: Transition $a \rightarrow b$
With the metal can immersed in the cold water, apply an external mass (~200 g, adjustable with the volume of the gas) on the platform to compress the air trapped inside the cylinder and metal can.
 - Isobaric expansion: Transition $b \rightarrow c$
Take the metal can out of the cold bath and place it in the hot water bath.
 - Isothermal expansion: Transition $c \rightarrow d$
While keeping the metal can in the hot water bath, remove the external mass from the platform.
 - Isobaric compression: Transition $d \rightarrow a$
Take the metal can out of the hot bath and put it back to the cold bath.
2. Calculating work with actual PV curve (Figure 7 is the experimental steps for the cycle)
- 1) Measure the air pressure and volume of the trapped air at all four points in the thermal cycle using the steps outline in part 1. Make sure to record the initial height of the cylinder for calculating the volume of the trapped air.
 - 2) Calculate the volume of the trapped air at four points of the thermal cycle, a , b , c , and d . (The air volume in the tubing and air cylinder is included !)
 - 3) Verify the processes $a \rightarrow b$ and $c \rightarrow d$ are approximately isothermal using the ideal gas law.
 - 4) Plot $P - V$ diagram and indicate those four points on the cycle. Mark the approximate isothermal and isobaric curves on the P vs. V diagram.
 - 5) Calculate the work W_1 done by the trapped air during the processes ($b \rightarrow c \rightarrow d$).
 - 6) Regard the cycle on the P vs. V diagram as approximately quadrilateral and calculate the area of the quadrilateral W_2 .

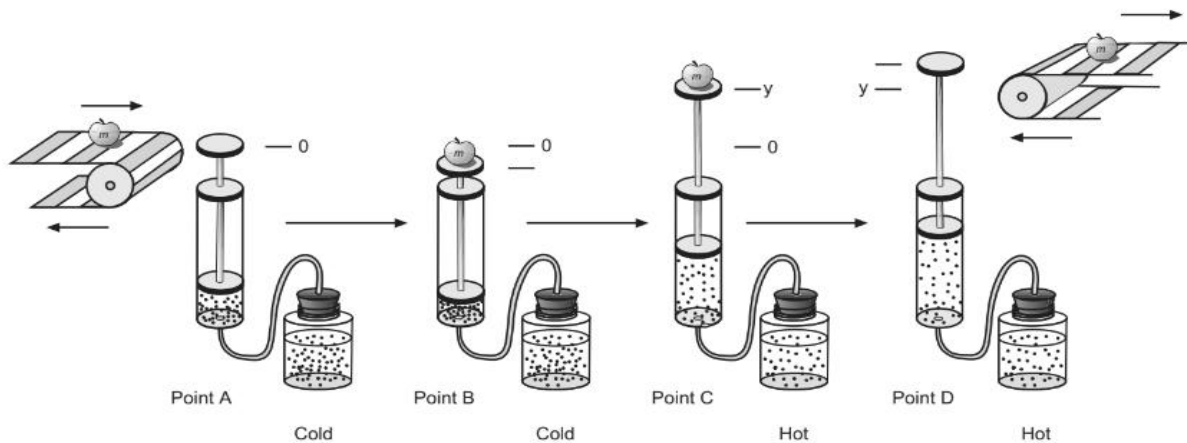

Figure 7. Schematics of experimental setup and operation steps for the thermal cycle.

Remarks :

1. To prevent damage to the instrument, when you use one hand to punch the piston in step 2 of procedure A, the other hand should hold the gas law apparatus steadily.
2. Check whether the piston slide down by itself after closing valve. If it does, the valve is not fully closed or the other port is not connected the low-pressure sensor properly.
3. In experiment of heat engine, use the proper weight. Leak rate is increased by a heavy load.
4. In experiment of heat engine, **avoid using very hot water for safety.**

Discussion hints :

1. Why is the temperature of water increased faster when boiling with a lid on compared to without a lid? Discuss the phenomena regarding the specific heat ratio.
2. When air is replaced by helium gas in experiment of specific heat ratio, how is the slope of T^2 vs. h line changed? Elaborate on it.
3. What are the constituents of the air? It is regarded as a diatomic molecule. Discuss the role of diatomic molecule in this experiment.
4. In experiment of heat engine, is the cycle curve on the P vs. V plot a closed loop? Describe and discuss the behavior of the curve.
5. State the physical meanings of W_1 and W_2 .

Magnetic Force on current-carrying wires

Objective :

By analyzing the relationship between the force on a current-carrying wire in a magnetic field and four variables - wire length, strength of the magnetic field, magnitude of current as well as the angle between the wire and the magnetic field, we can verify the Lorentz force.

Apparatus :

Magnetic force apparatus (current balance accessory unit, current loop PC board (PCB), horseshoe magnets, magnet assembly), power supply, Hall probe meter, electronic scales

Principle :

When a charged particle of charge q moves with velocity \vec{v} in the presence of electric field \vec{E} and magnetic field \vec{B} , it experiences a force that is called Lorentz force. The force can be expressed as follows.

$$\vec{F} = q(\vec{E} + \vec{v} \times \vec{B}) \quad (1)$$

When only a current-carrying wire in magnetic field instead, Force form is written as

$$\vec{F} = i\vec{L} \times \vec{B} \quad (2)$$

Thus, from the preceding equation, the magnitude and the direction of the force depend on the following four variables

1. current i
2. length of the wire L
3. magnitude of magnetic field B
4. angle between wire and magnetic field θ

In this experiment, we can change the above variables and measure the magnetic force to verify the Lorentz force equation.

Magnets are mounted on an iron yoke and placed on an electronic scale. One of the conducting paths of PCB is suspended between the magnets. The electronic scale is used to measure the mass of the magnets and yoke prior to any current passing through the conducting path. Current is then passed through the conducting path, producing a magnetic force either upward or downward. Based on the Newton's third law of motion, the action and reaction have the same magnitude but in opposite direction. The change in reading on the electronic scale can be converted to find the magnetic force between the conductor and magnetic field.

Instruction of the Hall probe meter

(a) Preparation for before operating (figure 1)

1. Plug the probe into the Hall Meter.
2. Make sure the Mode: PSU-5 transformer should be connected before **ON/OFF** button be turned on.
3. Prepare the zero-flux chamber.
4. After pressing the **ON/OFF** button, the display will show "CAL6~CAL0" (now, the Hall meter is conducting self-adjustment.)

(b) Selection of measurement units

1. Press **SHIFT**, then press **←** (choose UNITS) and use **↑/↓** to select the unit you need. The unit needed in this experiment is "T" (or mT).
2. After choosing the unit, press **SHIFT** and use **←** to confirm it.



Figure 1. Photo of a Hall Probe Meter

If the monitor shows up "AUTO RANGE", the Hall meter is set on automatic position function. If there is no "AUTO RANGE", press **SHIFT** and choose **RANGE** to select the function.

(c) Zeroing

1. Insert the probe into the zero-flux chamber.
2. And press **ZERO** to zero it. If you hear the sound "beep beep" from machine, the zeroing process has been completed.

(d) Magnitude measurement of the magnetic field

1. Put the front end of the probe to the magnetic field.
2. Moves the probe to check the reading.
3. The surface of the probe is required to be perpendicular to the magnetic field and away from magnets.
4. The reading is the magnitude of magnetic field at the front end of the probe.

(e) Polarity measurement of the magnetic field

Put the probe into a magnetic field, if the value of the magnetic field is positive then the magnet surface faces to F.W BELL is the polarity of “N”. If the value is negative, it’s “S”.

Remarks :

1. Be careful with the probe of Hall Meter, which is fragile and very expensive.
2. If the probe isn’t used, be sure to put on the protective sleeve in case of damage.
3. While plugging in the probe, make sure the direction of the connector’s pins to prevent from fracturing.
4. Before turning on the power of Hall Meter, plug in the sensor probe first. After the measurement, turn off the power first and then unplug the probe.
5. Before using Tesla Meter, check the manual to learn how to reset it to zero.
6. Never weigh any object that will exceed the capacity of an electronic scale, which is about 600.00 grams.
7. The maximum load of the Current Loop PCB is 2.00 A, the maximum load of the Current Balance Accessory Unit is 5.00 A.
8. Don’t mix the power transformer between Hall Meter and electronic scale, or it will damage the sensitive device due to specific tolerance of the machine.
9. Make sure that reading of electronic scale is not influenced by air condition.

Procedure :

A. Investigating the relation between the arrangement of magnets and magnitude of magnetic field

1. Mount six horseshoe magnets in the magnet assembly.
2. Measure and record the magnitude of the magnetic field B in the indentation of the magnet assembly with the Hall Meter.
3. Move to probe to observe the change of the magnetic field with respect to distance from magnets.
4. Check the change of magnetic field due to the arrangement of magnets.

B. Investigating the relation between the force magnitude F and current i while keeping the same wire length L and magnitude of magnetic field B

1. Begin by assembling the experiment as shown in figure 2.
2. Mount six horseshoe magnets in the magnet assembly. Make sure that the direction of North and South poles of the magnets are the same.
3. Measure and record the magnitude of the magnetic field B in the indentation of the magnet assembly with the Hall Meter.
4. Insert the No.6 Current Loop PCB ($L = 8.40$ cm) into the end of the Main Unit to make electric connections.
5. Put the magnet assembly on an electronic scale and place the Current Loop PCB between the two poles of magnets. Mark the mass of the magnet assembly while no current flowing as m_1 .
6. Set the current to 0.50 A, and record the new “mass” of the magnet assembly. Mark this value as m_2 .
7. Using the difference of mass to determine the force magnitude F on the wire.
8. Vary current (no exceed 2.00 A) and repeat above steps.
9. Plot F vs. i .

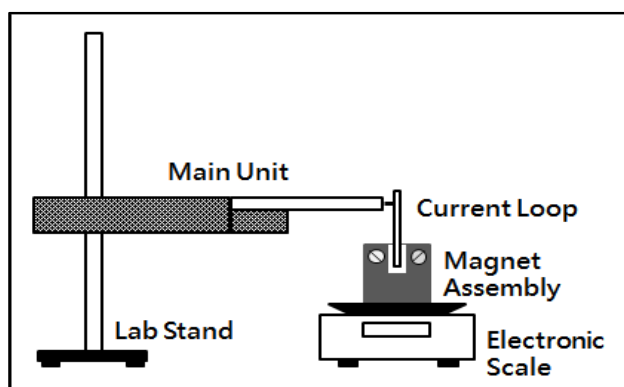

Figure 2. Schematic of experimental setup I.

C. Investigating the relation between the force magnitude F and wire length L while keeping the same current i and magnitude of magnetic field B

1. Begin by assembling the experiment as shown in figure 2.
2. Mount six horseshoe magnets in the magnet assembly. Make sure that the direction of North and South poles of the magnets are the same.
3. Measure and record the magnitude of the magnetic field B in the indentation of the magnet assembly with the Hall Meter.
4. Insert the No.6 Current Loop PCB ($L = 8.40$ cm) into the end of the Main Unit to make electric connections.
5. Put the magnet assembly on an electronic scale and place the Current Loop PCB between the two poles of magnets. Mark the mass of the magnet assembly while no current flowing as m_1 .

- Set the current to 1.50 A, and record the new “mass” of the magnet assembly. Mark this value as m_2 .
- Using the difference of mass to determine the force magnitude F on the wire.
- Vary the wire length by using different current loop PC board (Table.1) and repeat above steps
- Plot F vs. L .

Table 1. Wire lengths of various Current Loop PCBs.

Number #	1	2	3	4	5	6
Length L (cm)	2.20	4.20	3.20	1.20	6.40	8.40

D. Investigating the relation between the force magnitude F and magnetic field magnitude B while keeping the same wire length L and current i

- Begin by assembling the experiment as shown in figure 2.
- Mount six horseshoe magnets in the magnet assembly. Make sure that the direction of North and South poles of the magnets are the same.
- Measure and record the magnitude of the magnetic field B in the indentation of the magnet assembly with the Hall Meter.
- Insert the No.4 Current Loop PCB ($L = 1.20$ cm) into the end of the Main Unit to make electric connections
- Put the magnet assembly on an electronic scale and place the Current Loop PCB between the two poles of magnets. Mark the mass of the magnet assembly while no current flowing as m_1 .
- Set the current to 1.50 A, and record the new “mass” of the magnet assembly. Mark this value as m_2 .
- Use the difference of mass to determine the force magnitude F on the wire.
- Change the number of magnets to vary the magnetic field magnitude. Repeat the above steps and make sure the direction of North and South poles of the magnets are the same.
- Plot F vs. B .

E. Investigating the relation between the force magnitude F and the angle θ

- Begin by assembling the experiment as shown in figure3.
- Measure and record the magnitude of the magnetic field B in the indentation of the magnet assembly with the Hall Meter.
- Insert the current balance accessory unit into the end of the main unit to make electric connections and set the dial on the unit to 0.0° .
- Put square-shaped magnet assembly on an electronic scale. Mark the mass of the square-shaped magnet assembly while no current flowing as m_1 .

5. Set the current to 1.50 A. Change the direction of the square-shaped magnet assembly until its mass is the same as m_1 .
[Note] The force on the wire is zero when current is parallel with the magnetic field.
6. If the force is not zero, you can adjust the angle until the force becomes zero. Or now the value of angle ϕ is a calibration.
7. Rotate the dial for different angles, -90° , -60° , -45° , -30° , -20° , -10° , 0° , 10° , 20° , 30° , 45° , 60° and 90° and mark the corresponding masses of the square-shaped magnet assembly as m_2 .
8. Using the difference of mass to determine the force magnitude F on the wire.
9. Plot F vs. $\sin \theta$.

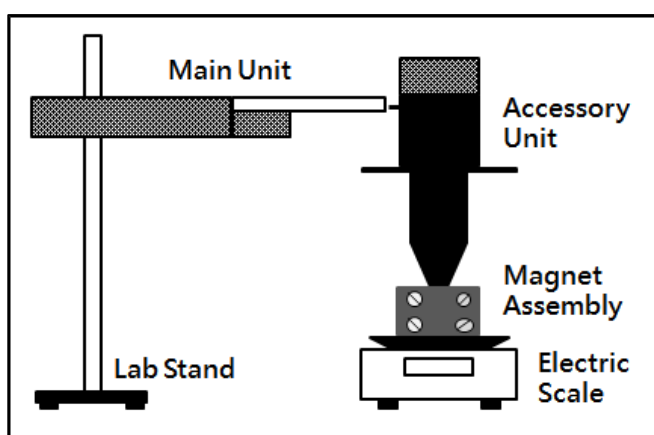

Figure 3. Schematic of experimental setup II. The total length is number of turns multiplied with 1.0 cm (length per turn).

Discussion hints :

1. Before using the Hall meter to measure the magnetic field, the zeroing process is required with inserting the probe into the zero-flux chamber. Describe the mechanism of the operation.
2. It has been known that the magnetic field is produced by a current. In the experiment, are your results affected by the field generated by the current? Elaborate on it.
3. In the experiment, are your results affected by the locations of PCB in the magnet assembly? Elaborate on it.
4. In procedure D, why use the No.4 Current Loop PCB ($L = 1.20$ cm) ? Elaborate on it.

Interferences and Diffraction of Light

Objective :

Using single-slit, double-slit, circular hole and grating to investigate the interference and diffraction phenomena of laser. Furthermore, by analyzing the interference and diffraction patterns on screen to obtain the wavelength of the laser.

Apparatus :

Optical track, diode laser, light sensor, rotary motion sensor, single-slit/double-slits/aperture assembly, grating assembly, graph papers, ruler, digital adaptor(blue ∙ PS-2159), analog adaptor(blue ∙ PS-2158), Air-Link(white ∙ PS-3200)x2, micro USB cable, Computer (software Capstone).

Principle :

A. Huygens's principle

In 1678, Huygens proposed that every point which a luminous disturbance reaches becomes a source of a spherical wave; the sum of these secondary waves determines the form of the wave at any subsequent time.

As shown in figure 1. He assumed that the secondary waves travelled only in the "forward" direction and it is not explained in the theory why this is the case.

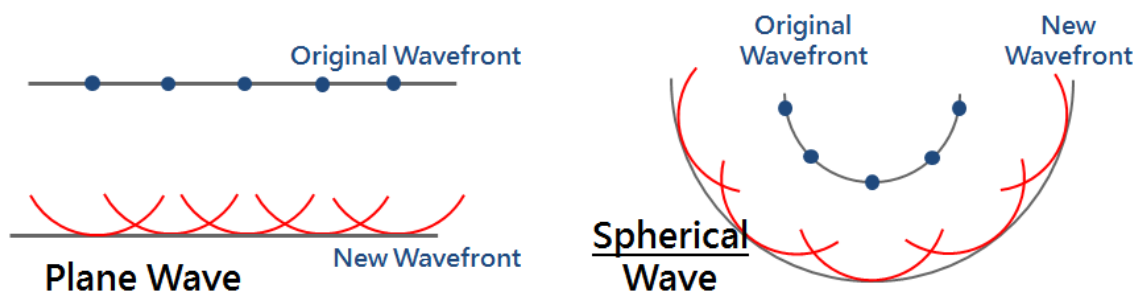

Figure 1. Schematics of plane wave and spherical wave

B. Double-slit interference

Young's double-slit experiment was one of the famous optics experiments in 19th century. Interference fringes can be seen on the screen far away when light source passes through a double-slit. The experiment established the theory of "wave optics". It also gave the principle of qualitative observation of "Wave Mechanics".

The phenomena of interference and diffraction are two remarkable features of the wave nature of light. A schematic diagram of the apparatus is shown in figure 2. Coherent plane waves arrive at opaque barrier which contains two parallel slits A and B. These two slits serve as a pair of coherent light source. The light from A and B produces on far away viewing screen

a visible pattern of bright and dark parallel bands called fringes. This phenomenon is so-called interference and it is a powerful evidence of wave nature of light. This is the famous Young's experiment performed in 1801.

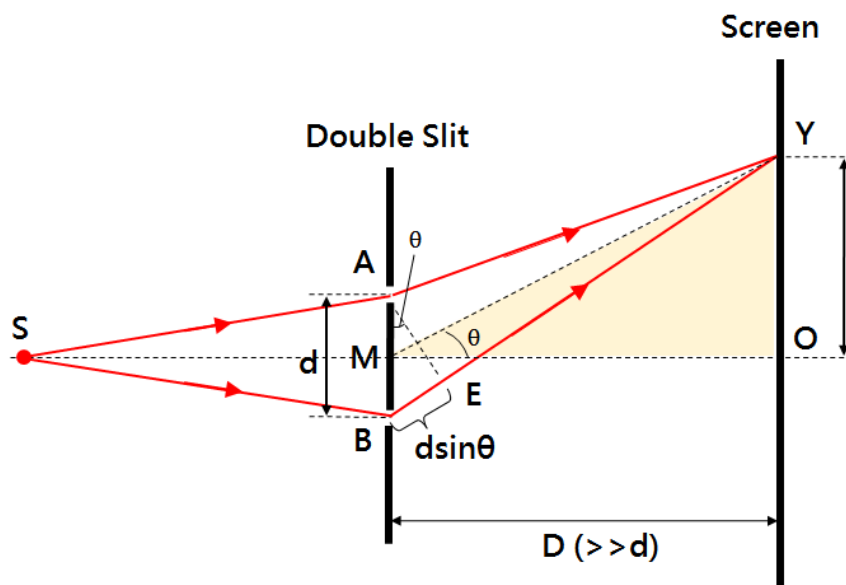

Figure 2. Geometric construction for describing Double-slit experiment (not to scale).

As indicated in figure 2 the distance from an arbitrary point Y on the screen to two slits A and B are \overline{AY} and \overline{BY} , respectively. Set position E on \overline{BY} , such that $\overline{EY} = \overline{AY}$. Then, the path difference is $\overline{BY} - \overline{AY} = \overline{BY} - \overline{EY} = \overline{BE}$.

If the screen is very far from the slits ($D \gg d$), then $\angle AYE$ is minimal, so \overline{AY} , \overline{YM} , and \overline{BY} are approximately perpendicular to \overline{AE} , the path difference can be expressed as

$$\overline{BE} \sim d \sin \theta \sim d \tan \theta = d \frac{y_m}{D} \quad (\theta \ll 1 \approx 0) \quad (1)$$

1. Constructive interference

The interference fringes on the screen are bright when the path difference satisfies

$$d \sin \theta = m\lambda, \quad m = 0, 1, 2, 3 \dots \quad (2)$$

where λ is the wavelength of light and the number m is called the order number. $m=0$ for the central bright fringe, $m=1$ for the first order bright fringes, and so forth.

Therefore, the location of the m -th order bright fringe, y_m , measured from the central bright fringe ($m=0$), O , can be substituted into equation (2) giving λ

$$m\lambda = d \sin \theta \sim d \tan \theta = d \frac{y_m}{D}$$

$$\Rightarrow \lambda \sim \frac{dy_m}{mD} \quad (3)$$

2. Destructive interference

The interference fringes on the screen are dark when the path difference satisfies

$$d \sin \theta = \left(m - \frac{1}{2}\right) \lambda, \quad m = 1, 2, 3 \dots \quad (4)$$

where λ is the wavelength of light and the number m is called the order number. $m=1$ for the first order dark fringe, $m=2$ for the second order dark fringe, and so forth.

Therefore, the location of the m -th order dark fringe, y_m , measured from the central bright fringe ($m=0$), O , can be substituted into equation (4) giving λ .

$$\begin{aligned} \left(m - \frac{1}{2}\right) \lambda &= d \sin \theta \sim d \tan \theta = d \frac{y_m}{D} \\ \Rightarrow \lambda &\sim \frac{dy_m}{\left(m - \frac{1}{2}\right)D} \end{aligned} \quad (5)$$

In summary, the monochromatic light passes through the double slits producing a visible pattern of bright and dark on the screen. The interference fringes on the screen would be symmetric with respect to the middle point O .

C. Single-slit diffraction

According to the Huygens's principle that each point on the approaching wavefront acts as a source of secondary wavelets (as shown in figure.1), when waves start to spread into a single-slit, each portion of the slit acts as a source of light waves. Hence, light from one portion of the slit can interfere with another portion resulting in the diffraction pattern on the screen. When the light source, the slit, and the screen are positioned at sufficiently distant locales (in the far-field region), diffraction due to effectively parallel incident light is called Fraunhofer diffraction. Conversely, when the light source, the slit, and the screen are in closer proximity (in the near-field region), diffraction due to the significance of the curved wavefronts is called Fresnel diffraction.

A monochromatic light enters a single-slit from left side as shown in figure 3. (slit width AB , $\overline{AB} = b$) Each portion of the slit acts as a point source of light waves (black points). If the screen is very far from the slit ($D \gg b$), then $\angle AYB$ is infinitesimal. Let the midpoint of the slit is O' and $\angle YO'O = \theta$, then the path difference, $\overline{BY} - \overline{AY}$, can be expressed as

$$b \sin \theta \sim b \tan \theta = b \frac{y_m}{D}, \quad \theta \approx 0 \quad (6)$$

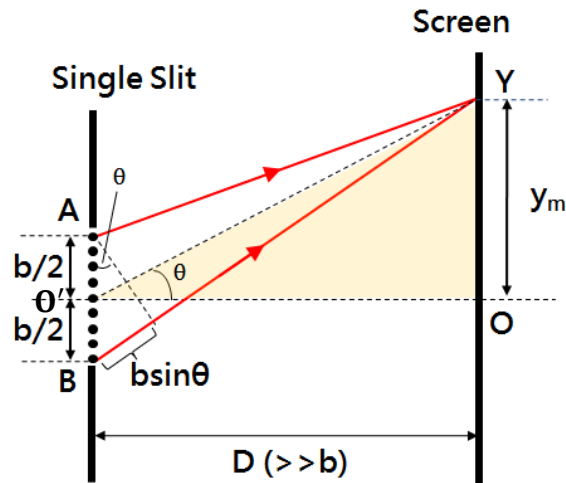

Figure 3. Geometric construction for describing single-slit experiment (not to scale).

1. Destructive interference

The interference fringes on the screen are dark when the path difference satisfies

$$b \sin \theta = m\lambda, \quad m = 1, 2, 3 \dots \quad (7)$$

where λ is the wavelength of light and the number m is called the order number. $m=1$ for the first order dark fringe, $m=2$ for the second order dark fringe, and so forth.

Therefore, the location of the m -th order dark fringe, y_m , measured from the central bright fringe ($m=0$), O , can be substituted into equation (7) giving λ .

$$\begin{aligned} m\lambda &= b \sin \theta \sim b \tan \theta = b \frac{y_m}{D} \\ \Rightarrow \lambda &\sim \frac{by_m}{mD} \end{aligned} \quad (8)$$

2. Constructive interference

A bright fringe is observed along the axis at $\theta=0$ and is called the central bright fringe. The intensity maximum is at point O , the center of the central bright fringe, for no path difference. Besides, other bright fringes on the screen can be observed when the path difference satisfies

$$b \sin \theta = \left(m + \frac{1}{2}\right) \lambda, \quad m = 1, 2, 3 \dots \quad (9)$$

where λ is the wavelength of light and the number m is called the order number. $m=1$ for the first order bright fringe, $m=2$ for the second order bright fringe, and so forth.

Therefore, the location of the m -th order bright fringe, y_m , measured from the central bright fringe ($m=0$), O , can be substituted into equation (9) giving λ .

$$\begin{aligned} \left(m + \frac{1}{2}\right) \lambda &= b \sin \theta \sim b \tan \theta = b \frac{y_m}{D} \\ \Rightarrow \lambda &\sim \frac{by_m}{\left(m + \frac{1}{2}\right) D} \end{aligned} \quad (10)$$

D. Double-slit interference and diffraction

Figure 4 is a plot of intensity of light versus position on the screen due to (a) interference and (b) diffraction effects in double-slit experiment. In double-slit experiment, each slit width cannot indeed be ignored and diffractions occur in addition to two-slit interferences. The combined effects of double-slit and single-slit result as shown in figure 4(c).

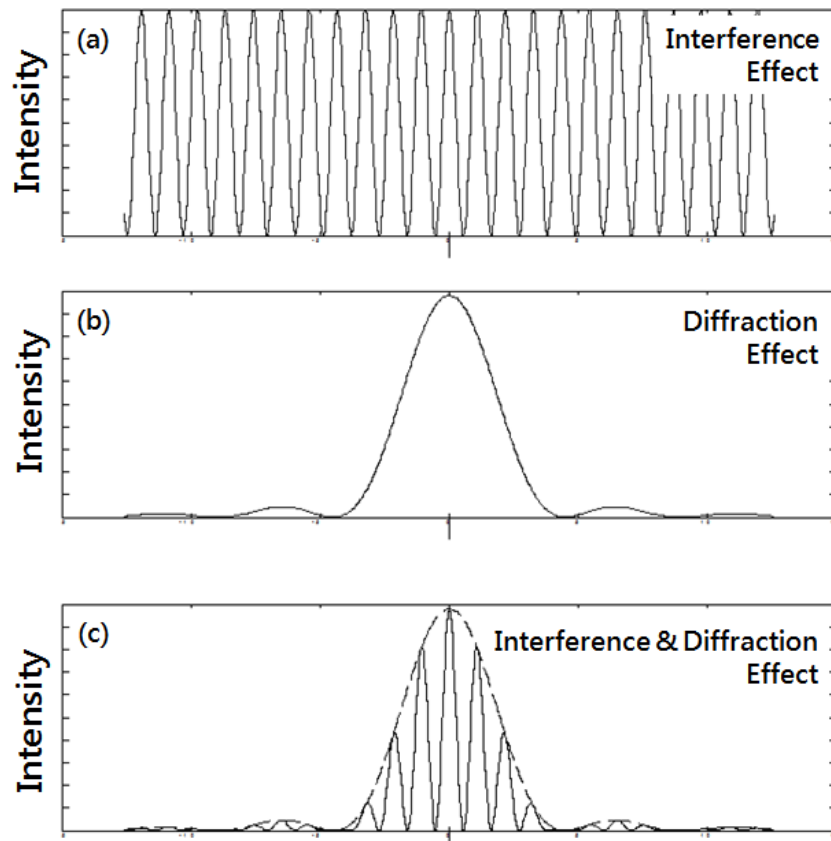

Figure 4. Plots of intensity of light versus position on the screen in double-slit experiment with consideration of (a) ideal double-slit interference, (b) ideal single-slit diffraction, and (c) combination of both effects, respectively.

E. Circular hole diffraction

As shown in figure 5, a coherent light passes through a circular hole resulting in a diffraction pattern of alternative bright and dark concentric circular rings on the viewing screen. Let the diameter of hole is b and the distance from the screen to the hole, D , is much bigger than b . In 1835, Airy derived the diffraction pattern of circular aperture using double integral method and the conditions for bright and dark rings as follows.

$$m\lambda = b \sin \theta \sim b \tan \theta = b \frac{y_m}{D}$$
$$\Rightarrow \lambda \sim \frac{by_m}{mD} \quad (11)$$

where λ is the wavelength of light and y_m is distance from either bright or dark ring to the center O.

Then $m = 0$ is the central bright disk, $m = 1.220$ is the first dark ring, $m = 1.635$ is the second bright ring, $m = 2.233$ is the second dark ring, $m = 2.679$ is the third bright ring, and $m = 3.238$ is the third dark ring.

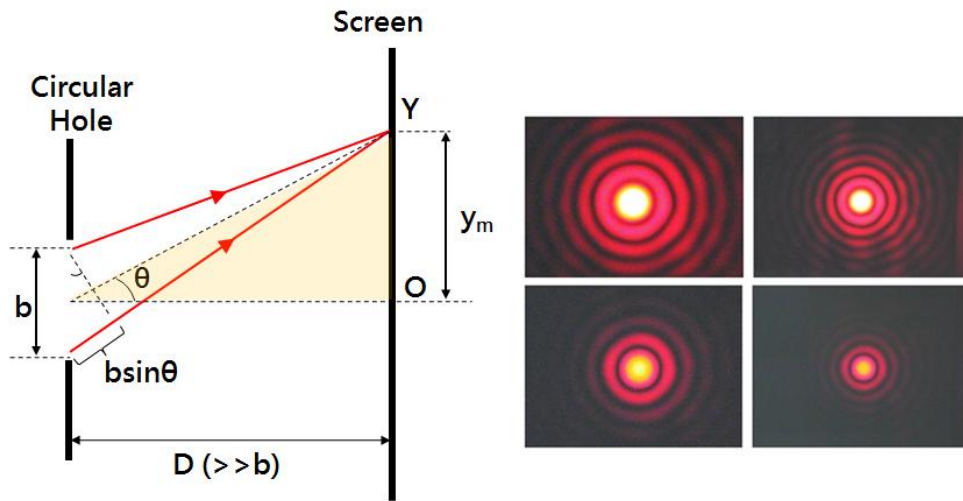

Figure.5 Circular hole diffraction

F. Grating diffraction

As shown in figure 6, on the viewing screen, light fringes will be formed due to interference and diffraction when parallel rays of light pass through the gratings once the following conditions are satisfied. As shown in figure 7, path difference between the light from adjacent slit can be expressed as $d \sin \theta$, where d is the distance between adjacent slits.

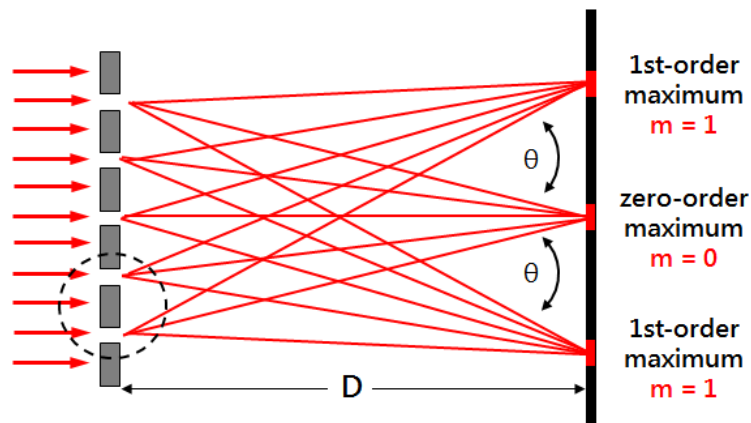

Figure 6. Grating diffraction (not to scale).

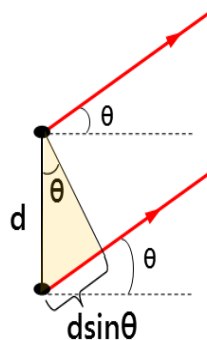

Figure 7. Schematic of path difference (enlarged view of dashed circle in fig.6)

If path difference is the integer multiple of λ , the waves arriving at point P on the screen are in phase and give rise to constructive interference.

$$d \sin \theta = m\lambda, \quad m = 0, \pm 1, \pm 2, \pm 3.. \quad (12)$$

$m = 0$ zero order maximum

$m = \pm 1$ first order maximum

$m = \pm 2$ second order maximum

Let D is the distance from viewing screen to grating and y_m is the distance from the m-th bright fringe to central fringe, then the wavelength of light can be expressed as following equation.

$$m\lambda = d \sin \theta \sim d \tan \theta = d \frac{y_m}{D}$$

$$\Rightarrow \lambda \sim \frac{dy_m}{mD} \quad (13)$$

Cautions :

1. Take extreme care when activating laser. The human eye does not take kindly to laser light. Do not stare into beam or view directly with optical instruments. Take whatever precautions are necessary to ensure that no spurious or stray beams leave your experimental area where they may be absorbed by your, your partner's or some other unsuspecting individual's retina.
2. During operation, do not move laser. Once it is required, turn off laser or shade the laser beam before moving laser.
3. Take extreme care when handling optical components. Do not touch any optical surface including slits and gratings with your bare hands. The oils on your fingers will significantly degrade the performance of these optics, severely compromising your date.
4. Do not turn laser on and off frequently.
5. The laser beam is very sensitive to vibration of table. Act gently in the laboratory.

B. Single-slit diffraction

1. Put diode laser and slit assembly on the optical track. Pick one single-slit on the slit assembly. The distance from the viewing screen to slit should be equal to or greater than 80.00 cm.
2. Turn on the diode laser. Adjust the laser and the assembly (height and incident angle) to let light pass the single-slit and get a series of clear and symmetric fringes on the screen.
[Note 1] Symmetric pattern about the center O on the screen.
[Note 2] Pull or push rotary motion sensor on the track slowly in order to make all fringes pass through the light sensor that is attached to the rotary motion sensor.
3. Set all parameters and figure window in software “capstone” according the operational manual.
4. Press start button to start acquiring data and observe the 『Intensity - position』 with moving slowly the rotary motion sensor from one side to the other side of the track.
5. Find the position of each dark fringe to the center y_m and calculate the wavelength of light λ .
6. Find the widths of the central bright fringe and other bright fringes.
7. Change to other double-slits and repeat the above steps.

C. Circular hole diffraction

1. Put diode laser and slit assembly on the optical track. Pick one circular hole on the slit assembly. The distance from the viewing screen to assembly should be either equal to or greater than 80.00 cm.
2. Turn on the diode laser. Adjust the laser and the assembly (height and incident angle) to let light pass the circular hole and get a series of concentric bright rings on the screen.
[Note] Pull or push rotary motion sensor on the track slowly in order to make most of fringes pass through the light sensor that is attached to the rotary motion sensor.
3. Set all parameters and figure window in software “capstone” according the operational manual.
4. Press start button to start acquiring data and observe the 『Intensity - position』 with moving slowly the rotary motion sensor from one side to the other side of the track.
5. Find the position of each bright and dark rings to the center y_m and calculate the wavelength of light λ .
6. Change to other circular holes and repeat the above steps.

D. Grating diffraction

1. Put diode laser and grating assembly on the optical track. Pick one grating on the assembly. Then put a graph paper on the screen.
2. Turn on the diode laser. Adjust the laser and the assembly (height and incident angle) to let light pass the grating to get a series of clear and symmetric fringes on the graph paper.
3. Mark the location of the bright fringes on the graph paper.
4. Measure the distances from each bright fringe to the central bright fringe, y_m , and then, calculate the wavelength of light λ .
5. Change to other gratings and repeat the above steps.

Discussion hints :

1. What happens to the interference or diffraction fringe patterns if the slit is tilted with a small angle? Elaborate on it.
2. If we change the wavelength of the light source, what will happen to the interference or diffraction fringe patterns? Elaborate on it.
3. There was no laser in the Young's experiment. How could he demonstrate that light and matter can have dual characteristics of waves and particles? Elaborate on it.

Michelson Interferometry

Objective :

Understand the construction and operational mechanism of Michelson Interferometer, and use it to measure the wavelength of light and the refraction index of unknown transparent block.

Apparatus :

Michelson interferometer (include lens, beam splitter, and mirror), He-Ne laser, transparent block, screen, Screw micrometer, level, hex keys.

Principle :

British scientist Thomas Young did the experiment about interference in 1801. It was the first investigations about light interference. He let the light pass through two closely spaced narrow slits. The light would split into two parts, which is the so-called division of wavefront. He saw the fringes on the screen at some distance behind. Thomas Young established the theory of wave optics to explain this result.

Besides, using beam-splitter is another way to split the amplitude into two parts. This is the so-called division of amplitude which is the idea used to design the Michelson Interferometer. When light incident on the beam splitter, it is split into two portions that one is reflected beam and the other is transmitted beam. Then both beams are reflected by mirrors and reach to the screen. Recombination of both beam on the screen results in alternating bright and dark fringes of interferences.

Michelson interferometer

As shown in figure 1, light from a laser is incident on a beam splitter BS (Only the side with a reflective coating will reflect beam.). Half of the beam, labeled as ray 1, is reflected to fixed mirror M_1 which reflects the beam back again and then passes through beam-splitter BS, finally, arrives at the screen S. The other half of the beam, labeled as ray 2, would pass through the beam splitter BS first, is reflected by adjustable mirror M_2 , and then back to BS. Again, beam-splitter BS will reflect this beam to the screen S. When ray 1 and ray 2 overlap on the screen S, path difference of two beams ($L_1 \neq L_2$) may leads to the interference fringes.

[Note] One side of beam splitter is coated with a thin film to split the incident beam.

[Note] Both fixed mirror and adjustable mirror are for reflection of light.

Since the He-Ne laser has a small divergence angle, it is hard to observe fringes on the screen. A divergence spherical wave is formed by using a convex lens. Hence, a convex lens needs to be placed between the He-Ne laser and the beam-splitter BS to make the fringes clearly visible.

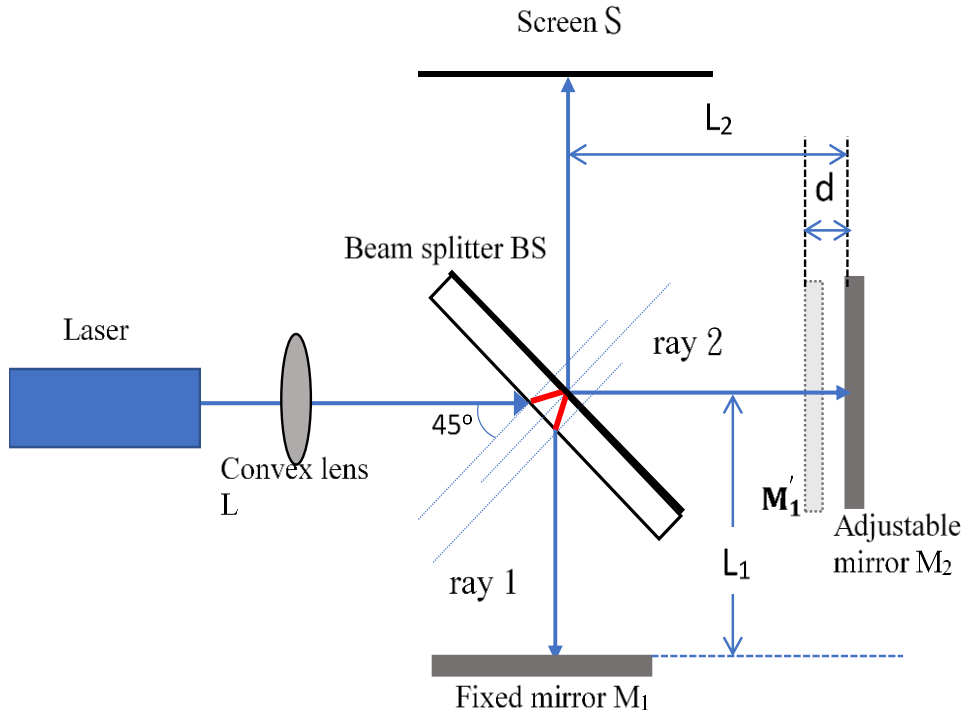

Figure 1. Schematic of Michelson Interferometer I.

When laser incident on the beam splitter of Michelson interferometer with an incidence angle 45° . Although each beam experiences a phase shift of 180° when it is reflected at the mirror surface. Ray 1 is reflected by the beam splitter and then, mirror M_1 while ray 2 is reflected by mirror M_2 and then, the beam splitter. Therefore, the bright fringe on screen is due to the constructive interference and the path difference of both rays is expressed as

$$2|L_1 - L_2| = n\lambda \quad (1)$$

where λ is the wavelength of the laser, n is the n th bright fringe.

The dark fringe on screen is due to the destructive interference and the path difference of both rays is expressed as

$$2|L_1 - L_2| = \left(n + \frac{1}{2}\right)\lambda \quad (2)$$

where λ is the wavelength of the laser, n is the n th bright fringe.

Figure 2 is schematic of some interference fringe patterns. When $L_1 = L_2$, assuming the adjustable mirror M_2 is located at M'_1 , there are bright out on screen without any interference fringe. Once shifting M_2 such that the longer related distance is achieved, more numbers of fringes and thinner fringe are present on screen. On the other hand, when M_2 is close to M'_1 , number of fringes is decreased and fringes are thicker on screen. Besides, with ray 1 is perpendicularly incident on the fixed mirror M_1 and ray 2 is slightly deviated from the normal incidence on the adjustable mirror M_2 , the interference patterns become the arc-shaped instead of circles on screen.

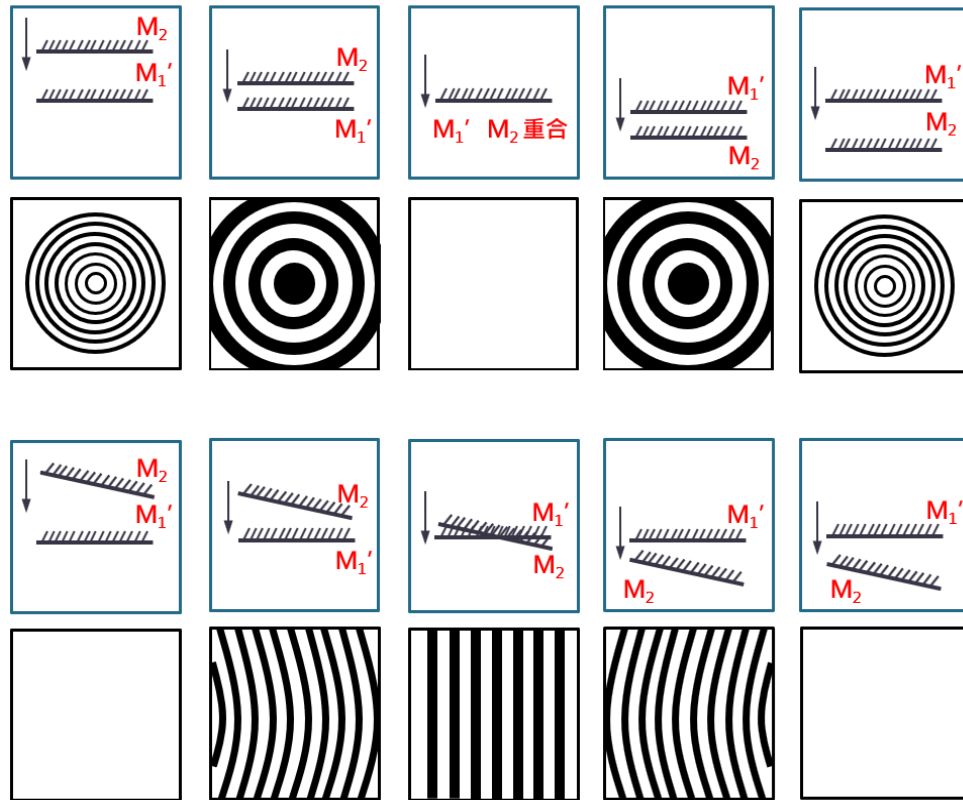

Figure 2. Schematics of interference fringe patterns with different locations of M_2 relative to M_1' .

In summary, when rays 1 and 2 are perpendicularly incident on the fixed mirror M_1 and the adjustable mirror M_2 , respectively, clear concentric circular fringes appear on screen. However, when ray 2 is slightly deviated from the normal incidence on the adjustable mirror M_2 , interference patterns change to be arc-shaped. With decreasing the path difference between L_1 and L_2 , the concentric circular fringes get wider. The first inner fringe shrinks and then, disappears at the center as the path difference is equal to $\lambda/2$. Note that the inference patterns are absent if the adjustable mirror M_2 is far away from M_1' .

A. Measure the wavelength λ of monochromatic light using Michelson interferometer

Viewing upon the center of all concentric fringes, according to equation (1) the bright center satisfies

$$2|L_1 - L_2| = n\lambda \quad (3)$$

Moving mirror M_2 such that distance $|L_1 - L_2|$ is d_1 and bright spot appear again on the center. Hence,

$$2d_1 = n_1\lambda \quad (4)$$

Keep moving M_2 such that distance $|L_1 - L_2|$ is changed to d_2 and bright spot appear again on the center. Again, the condition for the bright center fringe is

$$2d_2 = n_2\lambda \quad (5)$$

Let equation (5) minus equation (4) for the related change,

$$2(d_2 - d_1) = (n_2 - n_1)\lambda \quad (6)$$

Let $\Delta d = d_2 - d_1$ and $\Delta n = n_2 - n_1$, equation (6) is rewritten as

$$\lambda = \frac{2\Delta d}{\Delta n} \quad (7)$$

With shifting adjustable mirror M_2 along the original path by a distance $\Delta d = d_2 - d_1$, count the number of bright fringes entering or exiting on the center, $\Delta n = n_2 - n_1$. Based on equation (7), the laser wavelength λ can be obtained.

B. Measure the refraction index n of unknown transparent block using Michelson interferometer

Speed of light traveling in vacuum is denoted as $c = f\lambda_0$ with a value approximately of 3×10^8 m/s. It changes when traveling in different mediums. The wavelength of light changes, too. If the refraction index of the medium is n , the wavelength of light traveling in the medium can be expressed as $\lambda = \lambda_0/n$.

[Note] f is the frequency of light. λ_0 is the wavelength of light traveling in vacuum.

After observing concentric circular fringes on screen, mount the unknown transparent block on the rotational stage located between beam splitter and adjustable mirror. The refraction index of the block can be obtained by investigating the change of fringe pattern. In practice, the fringe pattern changes abruptly when the block is placed leading to quite a lot difficulty to get n . Hence, rotating the block instead to investigate the change of fringe pattern upon the rotational angle. The refraction index of the block n can be obtained by this method as shown in figure 3.

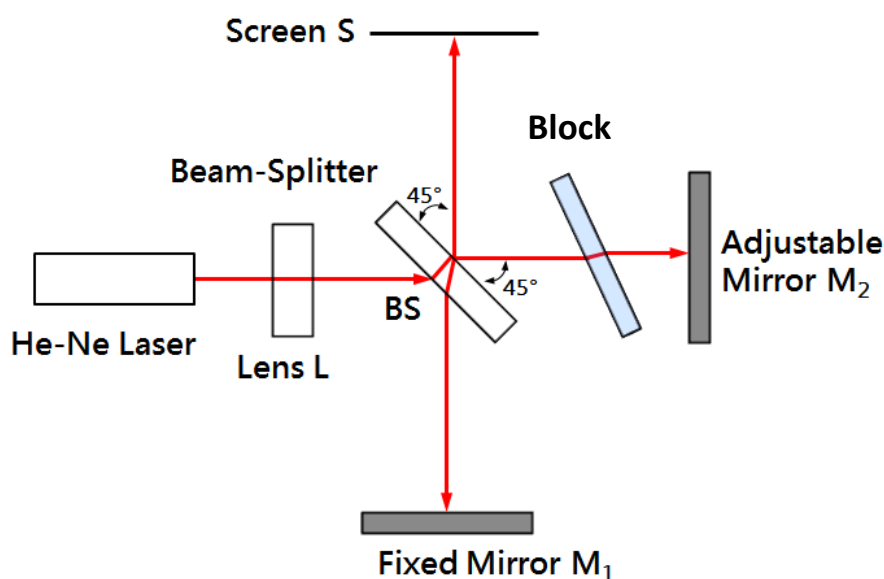

Figure 3. Schematic of Michelson Interferometer II.

If the block is rotated, the fringes enter or exit the center of the fringe pattern depending on the direction in which rotation take place. Let Δl is the path change due to the rotation of the block and Δm is number of fringe pass by. Both satisfy the following,

$$2\Delta l = \lambda\Delta m \quad (8)$$

At initial, light incident on the block perpendicularly as shown in figure 4. Then, the block is rotated such that the incidence angle is θ . According to Snell's law

$$n_0 \sin \theta = n \sin \varphi \quad (9)$$

where n is the refraction index of the block, n_0 is the refraction index of air ($n_0 \sim 1$), and n can be expressed as

$$n = \frac{\sin \theta}{\sin \varphi} \quad (10)$$

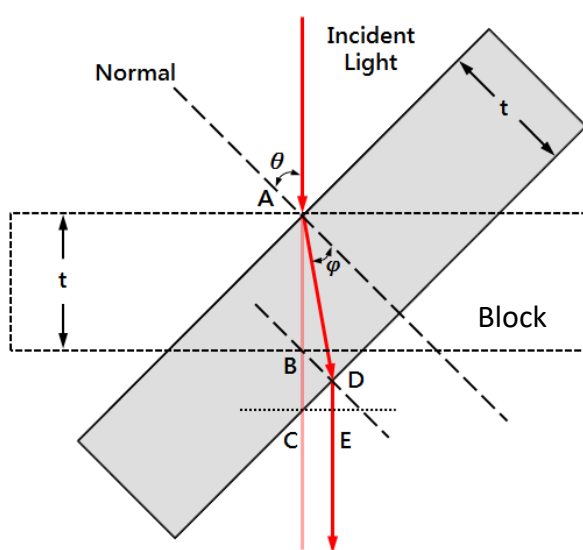

Figure 4. Path of light

As shown in figure 4, when light is normally incident on the block (dashed rectangle), the total optical path between A and C for the light going in one direction is $n\overline{AB} + \overline{BC}$. After rotating the block by an angle θ (solid rectangle), this path is increased to $n\overline{AD} + \overline{DE}$. Hence, the path change due to the rotation of the block, Δl , can be expressed as

$$\Delta l = (n\overline{AD} + \overline{DE}) - (n\overline{AB} + \overline{BC}) \quad (10)$$

Substitute equation (10) into equation (8)

$$2(n\overline{AD} + \overline{DE} - n\overline{AB} - \overline{BC}) = \lambda\Delta m \quad (11)$$

Let

$$\overline{AB} = t, \quad \overline{AD} = \frac{t}{\cos \varphi}, \quad \overline{BC} = \frac{t}{\cos \theta} - t, \quad \overline{DE} = \overline{CE} \tan \theta = \frac{t \sin(\theta - \varphi) \sin \theta}{\cos \varphi \cos \theta}$$

and then, the index of refraction of the block is

$$n = \frac{(1 - \cos \theta)(2t - \lambda\Delta m)}{2t(1 - \cos \theta) - \lambda\Delta m} \quad (12)$$

Cautions :

1. Take extreme care when activating laser. The human eye does not take kindly to laser light. Do not stare into beam or view directly with optical instruments. Take whatever precautions are necessary to ensure that no spurious or stray beams leave your experimental area where they may be absorbed by your, your partner's or some other unsuspecting individual's retina.
2. During operation, do not move laser. Once it is required, turn off laser or shade the laser beam before moving laser.
3. Take extreme care when handling optical components. Do not touch mirrors, lens, beam splitters, or any other optical surface with your bare hands. The oils on your fingers will significantly degrade the performance of these optics, severely compromising your date.
4. Do not turn laser on and off frequently.
5. The laser beam is very sensitive to vibration of table. Act gently in the laboratory.

Procedure :

A. Measuring the wavelength of monochromatic light of laser λ

1. Begin by assembling the experiment as shown in figure 5. (without the convex lens at the front of the interferometer)
2. Adjust screw micrometer to level optical table.
3. Adjust the screws on the back side of the fixed mirror M_1 to keep it parallel with the support frame
4. Turn on the He-Ne laser, adjust properly the location and height of the laser mount such that laser beam incident to the center of mirror M_2 perpendicularly after passing through BS.
5. Rotate BS such that laser beam incident on BS with an incident angle 45° .
6. Check the light spots of rays 1 and 2 reflected from M_1 and M_2 , respectively, on screen. Adjust slightly the screws on the back side of the fixed mirror M_1 to make both light spots overlap.
7. Put the convex lens back and adjust slightly its location until the concentric ring-shaped fringes appear on screen.
8. Rotate the screw micrometer to move M_2 either forward or backward to see bright fringes exiting or entering on the center

[Note] In the experiment, the traveling distance of M_2 , Δd , is one twenty-fifth of the traveling distance of the screw micrometer, ΔS . By counting the tick number of rotating screw micrometer, the traveling distance of M_2 , Δd , can be obtained.

$$\Delta s = \text{tick number of rotations} \times 0.01 \text{ (mm)}$$

$$\Delta d = \Delta s \times \frac{1}{25} \text{ (mm)}$$

9. Rotate the screw micrometer to move M_2 . Simultaneously count the number of fringes exiting or entering on the center Δn and calculate Δd .
10. Calculate the wavelength of light λ .

$$\lambda = \frac{2\Delta d}{\Delta n}$$

11. Repeat the above steps 8 and 9.
12. Plot Δd vs. Δn . Calculate the wavelength of light λ by linear regression.

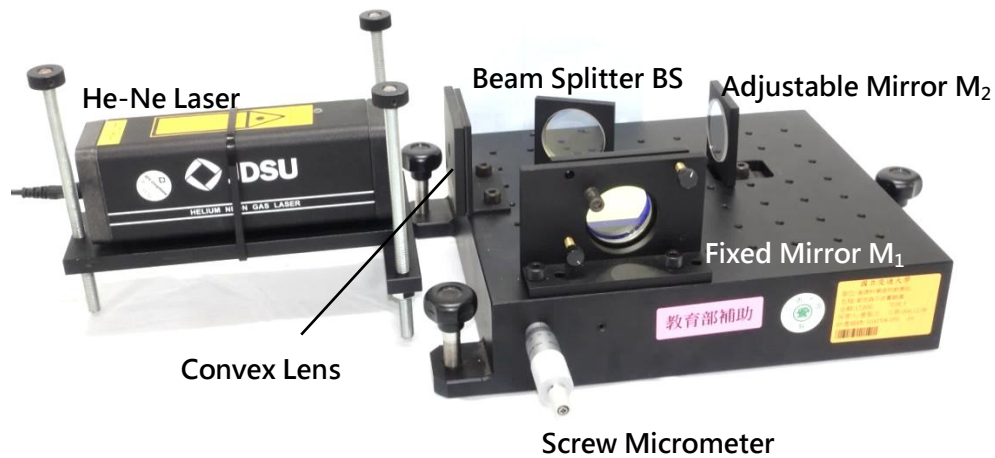

Figure 5. Photo of experimental set-up I.

B. Measuring the refraction index of transparent block n

1. Follow steps in part A to get the concentric circular fringes on screen.
2. Mount the transparent block on the rotational stage as shown in figure 6 and keep the light spot close to the center of the block.
3. Rotate the lever arm such that the pointer points close to the zero on the degree scale on the interferometer.
4. Rotate the lever arm by a certain of degree slowly to see the change of interference fringes on screen.
5. Count the number of fringes that pass by a fixed point Δm (≥ 10) with rotating the lever arm. Record Δm and corresponding rotating angle θ' .
6. Repeat the above steps for different rotating angles θ' (Δm).
7. Find the initial angle for the normal incidence on the block and calculate the refraction index of the block n .

[Note] Use screw micrometer to measure thickness of the transparent block t .

block holder



Figure 6. Photo of experimental set-up II.

Discussion hints :

1. What are the function of the beam splitter and its mechanisms? How to differentiate the coated surface? Elaborate on it.
2. What are the applications of Michelson Interferometer? Elaborate on it.
3. Whether the refraction index of the unknown block be obtained by changing the related displacement of it to the adjustable mirror M_2 instead of changing the incident angle of ray 2 on it? Elaborate on it.
4. Is it possible to obtain the refractive index of air at one atmospheric pressure using a Michelson interferometer? Elaborate on it.

Table 1. Refraction indices of some materials.

medium	vacuum	atmosphere	water	quartz	acrylic	window	flint glass	diamond
Refraction index	1	1.000 29	1.33	1.46	1.49	1.52	1.69	2.42

Basic Electrical Circuits

Objective :

1. Be aware of principle and structure of digital multimeters. Furthermore, use the multimeter to measure the Alternating Current (AC) / Direct Current (DC) signals.
2. Be familiar with the theory and operation of the oscilloscope. Moreover, interpret signals by the oscilloscopes.

Apparatus :

Digital multimeter, power supply, function generator, solderless breadboard, resistors, oscilloscope, BNC Tee adaptor, BNC to banana adaptors, coaxial cables (BNC to alligator, BNC to BNC)

Principle :

A. D'arsonval galvanometer

The top view of D'arsonval galvanometer is shown in figure 1. When current I passes through flexible coil, it interacts with the permanent magnet resulting in a clockwise torque $\vec{\tau}_1$ with the direction point into paper and magnitude in proportion to current I . It can be expressed as the following equation.

$$\tau_1 = KI \quad (1)$$

where K is the proportion constant.

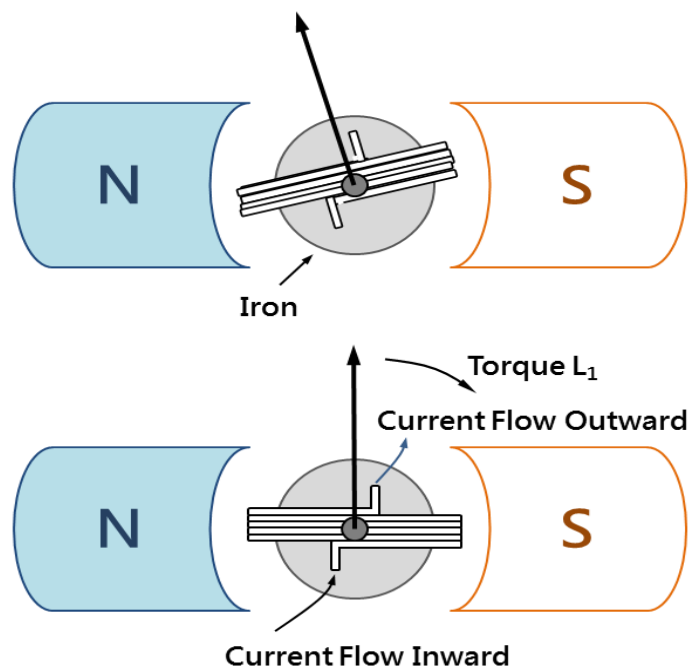

Figure 1. Diagram of D'arsonval galvanometer

This torque would cause the rotation of the coil. The twist of upper and lower springs causes the counterclockwise torque $\vec{\tau}_2$ with the direction point out of paper and magnitude in proportion to rotation angle θ . It can be expressed as the following equation.

$$\tau_2 = \kappa\theta \quad (2)$$

where κ is the proportion constant.

When the system is in equilibrium with both torques $\vec{\tau}_1$ and $\vec{\tau}_2$ cancel with each other. Hence,

$$\begin{aligned} KI &= \kappa\theta \\ \Rightarrow I &= \frac{\kappa}{K}\theta \end{aligned} \quad (3)$$

and we can find the current value by measuring the rotation angle of the indicator.

[Note] As shown in figure 2, there are two types of power supply: direct current (DC) and alternating current (AC). The current and voltage of direct current always stay constant independent of time. The current and voltage of alternating current would vary cyclically with time.

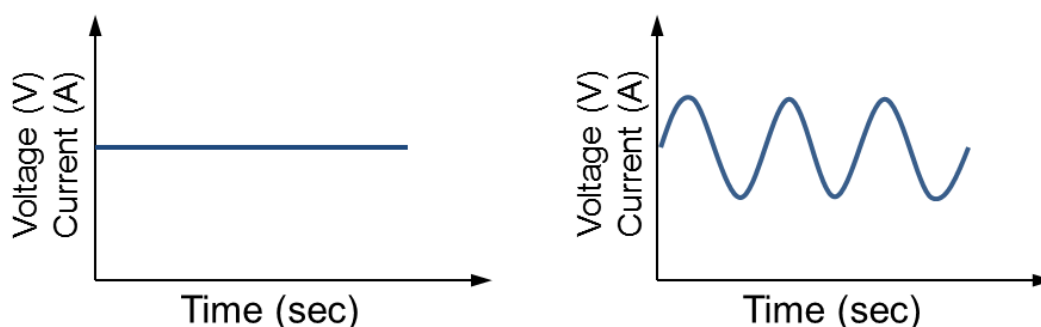

Figure 2. (Left) DC/(Right) AC signals: voltage and current versus time.

Thus, the circuit would act differently when you supply these two kinds of the power source. To explicate the differences, take electric power as an example.

(a) DC signal

When a resistor R carries a current I , the dissipation power P of the resistor is

$$P = I^2R \quad (4)$$

(b) AC signal

When a resistor R carries a sinusoidal current $I = I_{\max} \sin(2\pi t/T)$, the dissipation power P of the resistor is

$$\begin{aligned} P &= \frac{1}{T} \int_0^T R(I_{\max} \sin(2\pi t/T))^2 dt = \frac{RI_{\max}^2}{T} \int_0^T \left(\frac{1 - \cos(4\pi t/T)}{2} \right) dt \\ &= \frac{RI_{\max}^2}{T} \left(\frac{t}{2} - \frac{T \sin(4\pi t/T)}{8\pi} \right) \Big|_0^T = \frac{RI_{\max}^2 T}{2} = \frac{RI_{\max}^2}{2} = RI_{\text{rms}}^2 \end{aligned} \quad (5)$$

where I_{\max} is the maximum current (current amplitude) and T is the period. I_{rms} is defined as the root mean square current for describing the net effect of alternating current.

Hence, the average power of alternating signal is denoted by the effective current (root mean square current) instead of the maximum and minimum currents. It is more practical to use root mean square current for a time-averaged power. It means that 『 the time-averaged power dissipated on a resistor by an AC current is equivalent to the power dissipated on the resistor by a DC current 』 .

When either ac voltage or ac current is measured using a digital multimeter, the reading shown represents the RMS voltage V_{rms} or the RMS current I_{rms} .

$$V_{\text{rms}} = \frac{V_{\text{max}}}{\sqrt{2}} = 0.707V_{\text{max}} \quad (6)$$

$$I_{\text{rms}} = \frac{I_{\text{max}}}{\sqrt{2}} = 0.707I_{\text{max}} \quad (7)$$

where V_{max} is the maximum voltage (voltage amplitude) and V_{rms} is the root mean square voltage, as shown in figure 3.

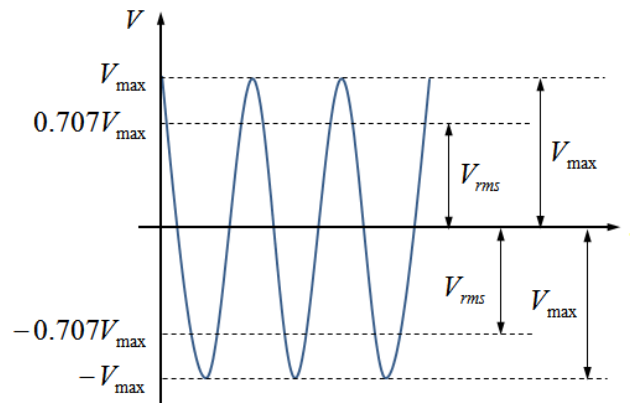

Figure 3. A sinusoidal alternating voltage : the root mean square and maximum voltages.

B. Ammeter: current measurement

As shown in Figure 4, when a galvanometer is used as an ammeter, a shunt resistor S is connected in parallel with the galvanometer G . Assume the internal resistance of galvanometer is R_g , the direct current which passes through the ammeter is I , and the direct current which passes through the galvanometer is I_f . According to Ohm's law, the value of the shunt resistance S is determined by the following equation.

$$\begin{aligned} R_g I_f &= S(I - I_f) \\ \Rightarrow I &= \left(\frac{R_g}{S} + 1 \right) I_f \end{aligned} \quad (8)$$

Thus, the measurement gear of the DC ammeter varies in accordance with shunt resistance S .

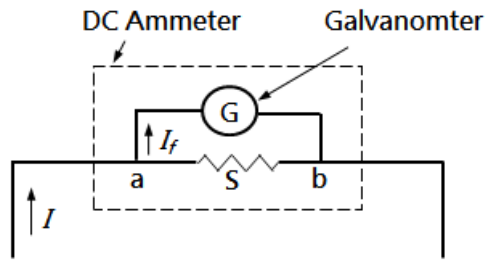

Figure 4. A DC ammeter.

For AC ammeter, it is formed with a galvanometer G , a small resistor S , and a rectifier. (A diode has the characteristic of low resistance under forwarding bias and high resistance under reverse bias.) Since D'arsonval galvanometer can only work with direct current, a rectifier is required to transform alternating current into direct current. Insert a rectifier into the left side of node a in figure 5 and it can be an AC ammeter. But please remember that the dial scale of an AC ammeter is the peak current times $0.707 (\sim 1/\sqrt{2})$.

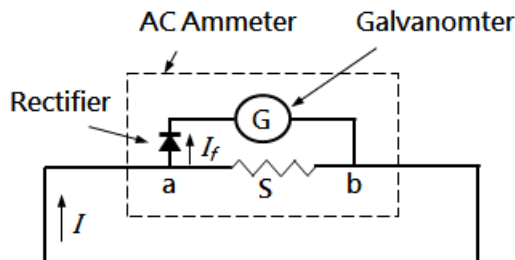

Figure 5. An AC ammeter.

C. Voltmeter: voltage measurement

As shown in Figure 6, when a galvanometer is used as a voltmeter, a large resistor R is connected in series with the galvanometer G . Assume the highest voltage measured by galvanometer is V_{\max} , the current at this time is I_{\max} , the internal resistance of the galvanometer is R_g , and then, $V_{\max} = R_g I_{\max}$. To obtain the highest voltage V in measurement, the resistor R we need to connect in series can be determined by the following,

$$V = (R + R_g)I_{\max} = RI_{\max} + V_{\max} \quad (9)$$

Therefore, the range of measured voltage is set by the resistance of the series resistor.

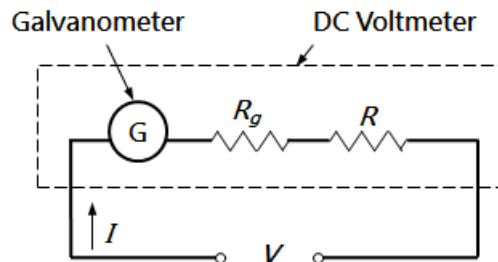

Figure 6. A DC voltmeter.

For an AC voltmeter, it would be the same as a DC voltmeter except that it requires one more rectifier.

D. Resistance measurement

Based on Ohm's law, the resistance of a resistor can be obtained by measuring the current through it and the voltage across its two ends.

$$R = \frac{V}{I} \text{ (Ohm's law)} \quad (10)$$

E. Oscilloscope

As shown in figure 7 (left), there are two types of Oscilloscope: analog and digital. The analog type mainly consists of a cathode ray tube (CRT). In a CRT, an electronic beam is generated from the cathode and then, is focused and accelerated to hit the fluorescent monitor, creating a spot on it. If an electric field is applied horizontally or vertically, the electric beam will deflect accordingly. Due to that the deflection is proportional to the voltage, we can measure the voltage by the deflection.

The voltage will be displayed on the monitor vertically. In order to observe the wave function, we have to add a set of deflection plate. Then this set of the plate is added with a time dependence electric field, making the spot spread horizontally, with the horizontal axis functioning as the time axis.

In contrast to an analog oscilloscope, a digital oscilloscope uses an analog-to-digital converter to convert the measured voltage into digital information. It acquires the waveform as a series of samples, and stores these samples until it accumulates enough samples to describe a waveform. The digital oscilloscope then re-assembles the waveform for display on the screen, as seen in figure 7 (right).

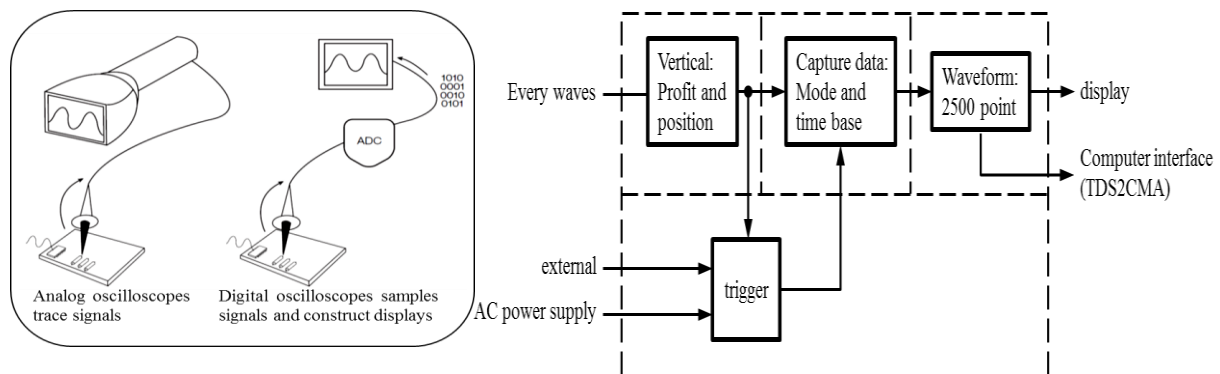

Figure 7. Oscilloscope principle schema

F. Function generator

Function generator signal generated by the oscillator, according to the frequency range can be divided into low frequency and high frequency two, low frequency signal generator, also known as audio signal generator, high frequency signal generator, also known as RF signal generator. Function generator can be used to test or troubleshoot circuit characteristics in various electronic instruments such as frequency response, gain, distortion, phase shift. So in the circuit repair, adjustment, testing is usually used with the oscilloscope.

G. Lissajous curves

Input two sinusoidal waves individually into vertical and horizontal terminals of the oscilloscope, and a continuous wave called Lissajous curve will be presented on the screen. When the frequency ratio is rational, the curve is closed and the pattern on the screen is stable (because the spot can “turn around” after a cycle). However, if the ratio is not rational, then the curve is open, and the pattern is unstable (Because the spot cannot turn back to the same place through the same phase, and the pattern we see is varying). Figure 8 (a) shows a closed pattern with ratio=2, and the pattern can be drawn through 0 to 24 points from figures 8 (b) and 8(c) for $y(t)$ and $x(t)$, respectively.

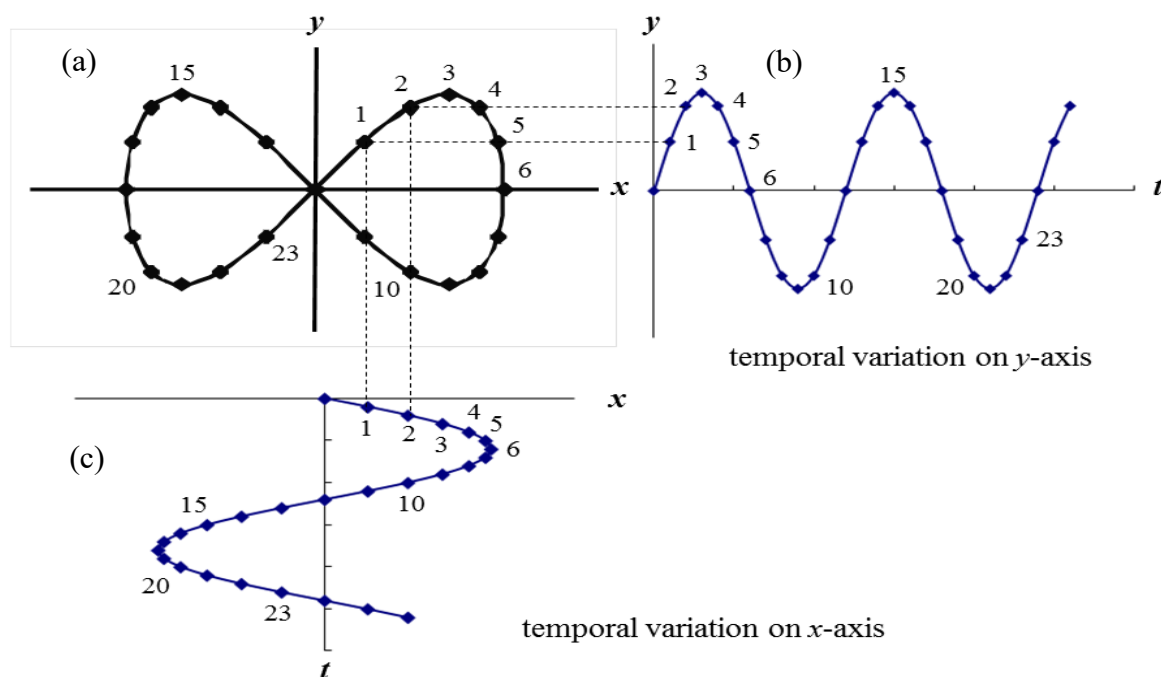

Figure 8. (a) A Lissajous curve with input components (b) $y(t)$ and (c) $x(t)$.

The appearance of the curve is sensitive to the frequency ratio and phase difference of two sinusoidal waves. The most famous pattern of Lissajous curves is that we can combine two sinusoidal waves with the same frequency, amplitude, but different phase to draw different closed patterns. For instance, the pattern is an ellipse, with special cases including circles (phase difference= $\pi/2$ radians) and lines (phase difference= 0). Table 1 lists the patterns with different frequency ratios and phase differences.

Table 1. Lissajous curves with different frequency ratios and phase differences

Phase difference $f_H:f_V$	0°	45°	90°	135°
1 : 1				
2 : 1				
3 : 1				
3 : 2				

Use the Lissajous curve to obtain the frequency ratio of two sinusoidal waves

Set oscilloscope at XY mode, when both input signals are sinusoidal, the Lissajous curve is displayed on the screen. Horizontal input (CH1) has the known frequency f_H and adjust the unknown frequency f_V of vertical input (CH2) until a stable curve as shown in table 1 appear.

Draw both horizontal and vertical lines in the Lissajous pattern. The crossing point of both lines is required in the enclosed region of the curve except the crossing points of the curve. Count the times the curve intercept with horizontal and vertical lines, n_H and n_V . The ratio is equal to the inverse ratio of two frequencies,

$$f_{CH1}:f_{CH2} = f_H:f_V = n_V:n_H \tag{11}$$

For instance,

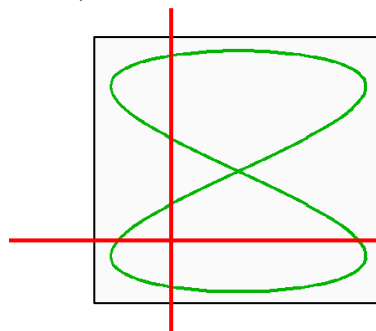

The times that curve intercept with horizontal line $n_H = 2$

The times that curve intercept with vertical line $n_V = 4$

$$\frac{f_{CH1}}{f_{CH2}} = \frac{f_H}{f_V} = \frac{n_V}{n_H} = \frac{4}{2} = \frac{2}{1}$$

Remarks :

1. Before the experiment, read the user guides of power supply (Appendix IV), the solderless breadboard (Appendix VIII), digital multimeter (Appendix V), and function generator (Appendix III).
2. When using the digital multimeter, make sure the circuit connection is correct. For scale switch, switch to the proper gear when measuring voltage or current. You should start with the maximum gear down to the minimum to prevent instruments from damage due to either shorted circuit or overload of current or voltage.
3. When measuring voltage, the digital multimeter should be in parallel with the circuit. ◦
4. When measuring current, the multimeter should be in series with the circuit. ◦
5. For the digital multimeter, never measure the voltage by current gear. If you do, it will cause fire and people might get hurt. Current more than 2 A should not input to the 2A terminal for small current measurement.
6. To avoid damage to the equipment, the output voltage of the power supply must not exceed 10.0 V.
7. Before the experiment, read the user guide of the oscilloscope (Appendix II) and figure out the function of each of the buttons and switches.
8. When you don't know what kind of signal displayed by the oscilloscope, press the 『AUTO SET』 button, but you should not rely too much on this function.
9. Power off all instruments after finishing experiment.

Procedure :

A. Measurements of DC voltage, DC current, and resistance

1. Pick two resistors and connect them in series on the breadboard. Record R_1 and R_2 . (check with table 2 and appendix VII)
2. Set the multimeter to resistance gear. Plug in the BNC to banana adaptor (bananas into V/R-COM input terminals of multimeter), BNC is connected to one end of coaxial cable (BNC/alligator). Both alligators on the other end of coaxial cable clip to both terminals of a resistor. Record both resistances of these two resistors, separately.
3. Setup the circuits in series and parallel on breadboard, as indicated in figure 9.
4. Supply direct voltage power (< 10.0 V) to series circuit and parallel circuit, respectively.
5. Power on digital multimeter. For dc voltage measurement, Press DCV button and connect the test leads from the two ends of the investigated resistor to the R/V and COM input terminals. After finishing, unplug leads from multimeter. Power off digital multimeter
※ Note: the investigated resistor is in parallel connection with meter.

- For dc current measurement, connect the test leads that one from the investigated resistor and the other from power supply to the I(20A) and COM input terminals. Make sure the connection is correct and then power on digital multimeter and press DCA button to measure total current and branch currents separately. You should start with the maximum gear down to the minimum

※ **Note: the investigated circuit is in series connection with meter.**

- Calculate the total voltage, shunt voltage, total current, and shunt current by Ohm's Law. Percentage errors should be included.

Table 2. Color Code

Black	Brown	Red	Orange	Yellow	Green	Blue	Violet	Grey	White	Gold	Silver
0	1	2	3	4	5	6	7	8	9	±5%	±10%

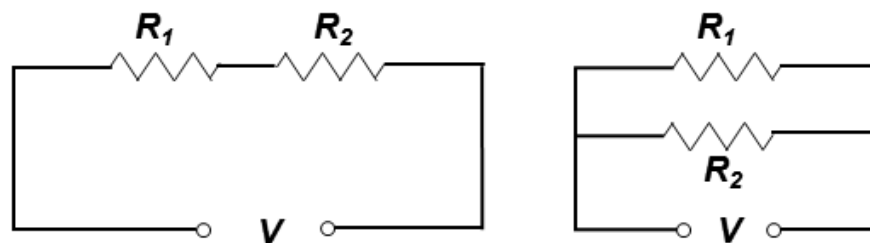

Figure 9. Schematics of (left) series and (right) parallel circuits

B. Measurement of AC voltage

- Turn on digital multimeter, press the function button (ACV).
- Plug in the BNC to banana adaptor (bananas into V/R-COM input terminals of multimeter), BNC is connected to one end of coaxial cable (BNC/BNC). The other end of coaxial cable plug in the main output of function generator(16, Appendix III) ◦
- Turn on function generator, set the output signal a sinusoidal wave of frequency 60 Hz. Record the variation of AC voltage readings with the amplitude of output voltage.
- While keeping the amplitude of output voltage fixed, record the variation of AC voltage readings by changing the frequency of output signal ranging from. 60 Hz to 1 MHz.

➤ Preparation of the oscilloscope

- Use BNC Tee adapter so that the output of the function generator can be the source of the circuit and simultaneously be the signal to CH1 of the oscilloscope.
- Set the output signal a sinusoidal wave of frequency 1.00 kHz.
- Adjust 「 VOLT/DIV 」 and 「 TIME/DIV 」 knobs of the oscilloscope such that 70% of the screen is covered by 1-2 periods of waves.

C. Voltage measurement

(a) Graticule measurement

1. Count the number of vertical graticule divisions from wave crest to trough.
2. Record the 「VOLTS/DIV」 of the wave. (On the lower left side of screen)
3. Calculate peak-to-peak voltage $V_{pp} = (\text{number of vertical graticule divisions that peak-to-trough voltage of the wave occupies}) \times (\text{VOLTS/DIV})$.
4. Calculate the amplitude voltage V_{max} and root mean square of voltage V_{rms} .

(b) Cursor measurement

Model TDS 2022

1. Press the **CURSOR** button to see CURSOR menu.
2. Press the **Type** option button to select 「voltage」, **Source** to select **CH1**.
[Note] The lights of cursor1 and cursor2 shall be on.
3. Turn the VERTICAL knobs of cersor1 and cersor2 to make two horizontal cursors in line with wave crest and trough.
4. Record values on the right of screen, cursor1, cursor2, and their difference delta that is the peak-to-peak voltage V_{pp} .
5. Calculate the amplitude voltage V_{max} and root mean square of voltage V_{rms} .

Model GDS 1152A-U

1. Press **CURSOR** button to see CURSOR menu.
2. Press **source** to choose 「CH1」, and **X ↔ Y** to choose horizontal cursor.
3. Press **Y1** and turn the VARIABLE knob to make the horizontal cursor in line with the wave crest.
4. Press **Y2** and turn the VARIABLE knob to make the horizontal cursor in line with the wave trough.
5. Record the values on the right of screen, Y1, Y2, and their difference that is the peak-to-peak voltage V_{pp} .
6. Calculate the amplitude voltage V_{max} and root mean square of voltage V_{rms} .

(c) Automatic measurement

Model TDS 2022

1. Press the **MEASURE** button to see MEASURE menu.
2. Record readouts of CH1 on the right of screen, peak-to-peak voltage V_{pp} . If the channel is not displayed, do the following steps 3 and 4.
3. Press the top option button, the Measure 1 Menu appears. Press the **CH1 Menu** button

4. Press the **Source** option button to select **CH1**, press the **Type** option button to select **Pk-Pk**, and then, press **BACK** option button to return.
5. Calculate the amplitude voltage V_{\max} and root mean square of voltage V_{rms}

Model GDS 1152A-U

1. Press the **MEASURE** button to see MEASURE menu.
2. Record readouts of CH1 on the right of screen, peak-to-peak voltage V_{pp} . If the channel is not displayed, do the following steps 3 and 4.
3. Press the corresponding menu button **F3** (F1~F5) to select the measurement slot to be edited.
4. Turn the VARIABLE knob to select measurement item, V_{pp} , and then press **F3** again to return. Press the **Previous Menu** button to back to the measurement results view.
5. Calculate the amplitude voltage V_{\max} and root mean square of voltage V_{rms} .

(d) Digital Multimeter measurement

1. Measure the root-mean-square voltage V_{rms} by a digital multimeter.
2. Calculate the amplitude voltage V_{\max} and peak-to-peak voltage V_{pp} .

D. Frequency measurement

(a) Graticule measurement

1. Count the number of horizontal graticule divisions of a period of the waveform.
2. Record the 「TIME/DIV」 of the wave. (On the bottom of screen)
3. Calculate period $T = (\text{number of horizontal graticule divisions of a period}) \times (\text{TIME/DIV})$.
4. Calculate frequency f .

(b) Cursor measurement

Model TDS 2022

1. Press the **CURSOR** button to see CURSOR menu. °
2. Press the **Type** option button to select 「Time」, **Source** to select **CH1**.
[Note] The lights of cursor1 and cursor2 shall be on.
3. Turn the VERTICAL knobs of cersor1 and cersor2 to make two vertical cursors in line with nearest neighboring wave crests.
4. Record values on the right of screen, cursor1, cursor2, and their difference delta that is the period T .
5. Calculate frequency f °

Model GDS 1152A-U

1. Press the **CURSOR** button to see CURSOR menu
2. Press **source** to choose 「CH1」, and **X ↔ Y** to choose vertical cursor.
3. Press **X1** and turn the VARIABLE knob to make the vertical cursor in line with the wave crest.
4. Press **X2** and turn the VARIABLE knob to make the vertical cursor in line with the next wave crest.
5. Record the values on the right of screen, X1, X2, and their difference that is the period T .
6. Calculate f .

(c) Automatic measurement

Model TDS 2022

1. Press the **MEASURE** button to see MEASURE menu
2. Record readouts of CH1 on the right of screen, period T and frequency f . If the channel is not displayed, do the following steps 3 and 4.
3. Press the top option button, the Measure 1 Menu appears. Press the **CH1 Menu** button. Press the **Source** option button to select **CH1**, press the **Type** option button to select **Period**, and then, press **BACK** option button to return.
4. Press the second option button from the top, the Measure 2 Menu appears. Press the **Type** option button to select **Freq**, and then, press **BACK** option button to return.
5. Record period T and frequency f .

Model GDS 1152A-U

1. Press the MEASURE button to see MEASURE menu.
2. Record readouts of CH1 on the right of screen, period T and frequency f . If the channel is not displayed, do the following steps 3 and 4.
3. Press the corresponding menu button **F3** (F1~F5) to select the measurement slot to be edited.
4. Turn the VARIABLE knob to select measurement items, period T and frequency f , and then press **F3** again to return. Press the **Previous Menu** button to back to the measurement results view.
5. Record period T and frequency f .

E. Transmission speed of signal in the cable

1. Pick two coaxial cables (BNC/BNC) of lengths 1 m and 60 m, respectively.
2. Plug BNC Tee adaptor to function generator. Connect each BNC end of these two coaxial cables to the BNC Tee adaptor. The other end of these two coaxial cables are connected to CH1 and CH2 of the oscilloscope, respectively.
3. Power on function generator and set the output signal to a sinusoidal wave of frequency about 1.0 MHz.
4. Use cursor method to find time interval between two nearest neighboring wave crests of CH1 and CH2, Δt .
5. Calculate speed of transmission, v .

$$v = \frac{\Delta d}{\Delta t} \quad \text{where } \Delta d \text{ is the length difference of two cables.}$$

6. Repeat the steps above for transmission frequency ranging from 1.0 MHz to 2.2 MHz with an increment of 0.3 MHz in each step.

F. Lissajous curves

1. Pick two coaxial cables (BNC/BNC) of about same length.
2. Input two sinusoidal waves of different frequency by two function generators separately into CH1 and CH2 of the oscilloscope.

Model TDS 2022

3. Adjust separately Ch1 and CH2 to 5 VOLT/DIV. (displayed on the left bottom of screen)
4. Press the **DISPLAY** button to select **XY** and then Lissajous pattern is displayed.
5. Based on Lissajous patterns shown in table 2, calculate the frequency ratio of these two sinusoidal waves.

Model GDS 1152A-U

3. Adjust separately Ch1 and CH2 to 5 VOLT/DIV. (displayed on the left bottom of screen)
4. Press **MENU** on HORIZONTAL panel to choose **XY** and then, Lissajous pattern is displayed.
5. Based on Lissajous patterns shown in table 2, calculate the frequency ratio of these two sinusoidal waves.

Discussion hints :

1. Are the measured values and calculated values the same in DC voltage measurement? What is the reason for the difference? Elaborate on it.
2. In AC voltage measurement, while keeping the output amplitude is fixed, are the measured AC voltage values changed with output frequency? Elaborate on it.
3. What is the influence of different frequencies to the transmission speed? Why do we adopt the high frequency in the experiment? Elaborate on it.
4. Student A talks to student B via phone. Student A finds out he always hears echo of his voice 100 ms after he speak. Assume that the frequency of carrier wave of the voice signal is 1.5 MHz. Please estimate the distance between student A and B? Elaborate on it.

RLC series circuits

Objective :

Study the damped oscillation and the characteristic frequency of RLC series circuits. The former is excited by a square wave of low frequency and the latter is excited by a sinusoidal signal, respectively.

Apparatus :

Oscilloscope, function generator, resistor, capacitor, inductor, BNC Tee adapter, coaxial cables(BNC to BNC, BNC to banana).

Principle :

A system can oscillate when it has two ways of storing energy and the energy can flow alternately from one mode of storage to the other. In an electric circuit which contains an inductor L and a capacitor C , energy can be stored in the magnetic field of L or in the electrostatic field C . As the flow of current discharges C , a magnetic field is developed around L . As the magnetic field decays, the induced voltage causes C to charge with a polarity opposite to the original one. Then the process reverses. This switching frequency is called the eigenfrequency of the LC circuit. An RLC circuit contains not only L and C but also a resistor R , which dissipates a certain fraction of the energy during each cycle. The eigenfrequency of the RLC circuit is also the voltage versus time on the capacitor or the magnetic field versus time on the inductor.

In the RLC circuit, we must provide a way of introducing current and a way of observing oscillation. In the circuit of figure 1, the RLC series circuit is connected to the function generator, supplying the voltage and current. The oscillation of charge in the loop can be studied by observing the potential across C with an oscilloscope.

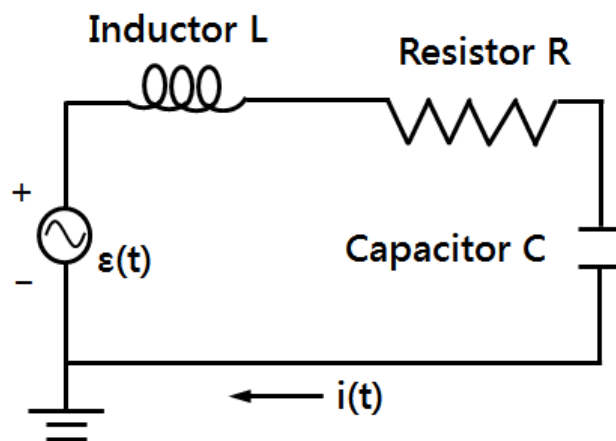

Figure 1. Schematic of a RLC series circuit.

From Kirchoff's rules, the algebraic sum of the changes in potential around a closed loop is zero. Therefore, the equation for this RLC circuit is written as

$$V_R(t) + V_L(t) + V_C(t) = \varepsilon(t) \quad (1)$$

Where $\varepsilon(t)$ is the emf (Electromotive force) supplied by the function generator. $V_R(t)$, $V_L(t)$, and $V_C(t)$ are the potentials across the resistor R, the inductor L, and the capacitor C, respectively.

The characteristics of the resistor R, the inductor L, and the capacitor C can be expressed by current $i(t)$ in the RLC series circuit.

$$1. \text{ Characteristics of C : } C = \frac{Q(t)}{V_C(t)} \ \& \ i(t) = \frac{dQ(t)}{dt} \Rightarrow i(t) = C \frac{dV_C(t)}{dt}$$

$$2. \text{ Characteristics of R (Ohm's Law) : } R = \frac{V_R(t)}{i(t)} \Rightarrow V_R(t) = i(t)R = RC \frac{dV_C(t)}{dt}$$

$$3. \text{ Characteristics of L : } L = \frac{d\Phi(t)}{di(t)} \ \& \ V_L(t) = \frac{d\Phi(t)}{dt} \Rightarrow V_L(t) = L \frac{di(t)}{dt} = LC \frac{d^2V_C(t)}{dt^2}$$

Substitute all characteristics into equation (1) and get the second order differential equation for the potential across the capacitor $V_C(t)$.

$$\frac{d^2V_C(t)}{dt^2} + \frac{R}{L} \frac{dV_C(t)}{dt} + \frac{1}{LC} V_C(t) = \frac{1}{LC} \varepsilon(t) \quad (2)$$

The solution of equation (2) depends on $\varepsilon(t)$, the emf supplied by the function generator.

A. $\varepsilon(t)$ is a square wave signal of low frequency (DC)

The function generator generates a square wave of low frequency, as shown in figure 2. Each times the square wave jumps from $+\varepsilon_0$ to $-\varepsilon_0$ or $-\varepsilon_0$ to $+\varepsilon_0$, the change in current sets RLC circuit into oscillation.

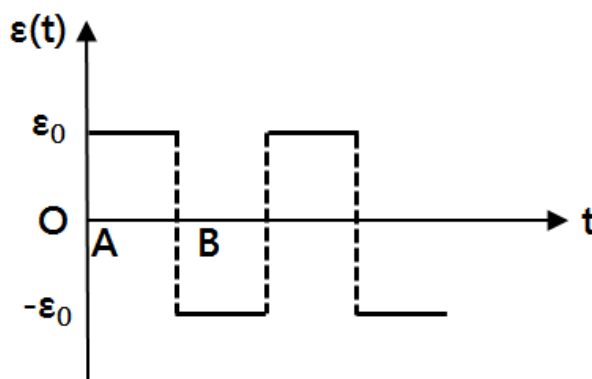

Figure 2. Square wave of $\varepsilon(t)$

There are two main processes

- i. At point A, potential jumps from $-\varepsilon_0$ to ε_0 : Capacitor is being charged until it is fully charged
- ii. At point B, potential jumps from ε_0 to $-\varepsilon_0$: Capacitor is discharging and then it is reversely charged with a polarity opposite to the original one.

Charging process :

Substitute $\varepsilon(t) = \varepsilon_0$ in equation (2) and the second differential equation can be represented as

$$\frac{d^2V_C(t)}{dt^2} + \frac{R}{L} \frac{dV_C(t)}{dt} + \frac{1}{LC} V_C(t) = \frac{1}{LC} \varepsilon_0 \quad (3)$$

Consider the initial condition, $V_C(t = 0) = -\varepsilon_0$, the solution of equation (3) is

$$V_C(t) = \varepsilon_0 \left(1 - 2 \sqrt{1 + \left(\frac{\beta}{\omega}\right)^2} e^{-\beta t} \cos(\omega t - \phi) \right)$$
$$\Rightarrow V_C(t) = \varepsilon_0 - 2\varepsilon_0 \sqrt{1 + \left(\frac{\beta}{\omega}\right)^2} e^{-\beta t} \cos(\omega t - \phi) \quad (4)$$

where $\beta = \frac{R}{2L}$, angular frequency $\omega = \sqrt{\frac{1}{LC} - \left(\frac{R}{2L}\right)^2}$, phase difference $\phi = \tan^{-1}\left(\frac{\beta}{\omega}\right)$

$$\text{amplitude } |V_C(t)| = 2\varepsilon_0 \sqrt{1 + \left(\frac{\beta}{\omega}\right)^2} e^{-\beta t}$$

$$\text{oscillation } \cos(\omega t - \phi)$$

Reverse charging process :

Substitute $\varepsilon(t) = -\varepsilon_0$ in equation (2) and the second differential equation can be represented as

$$\frac{d^2V_C(t)}{dt^2} + \frac{R}{L} \frac{dV_C(t)}{dt} + \frac{1}{LC} V_C(t) = -\frac{1}{LC} \varepsilon_0 \quad (5)$$

Consider the initial condition, $V_C(t = 0) = \varepsilon_0$, the solution of equation (3) is

$$V_C(t) = 2\varepsilon_0 \sqrt{1 + \left(\frac{\beta}{\omega}\right)^2} e^{-\beta t} \cos(\omega t - \phi) - \varepsilon_0 \quad (6)$$

where $\beta = \frac{R}{2L}$, angular frequency $\omega = \sqrt{\frac{1}{LC} - \left(\frac{R}{2L}\right)^2}$, phase difference $\phi = \tan^{-1}\left(\frac{\beta}{\omega}\right)$

$$\text{amplitude } |V_C(t)| = 2\varepsilon_0 \sqrt{1 + \left(\frac{\beta}{\omega}\right)^2} e^{-\beta t}$$

$$\text{oscillation } \cos(\omega t - \phi)$$

By equations (4) and (6), $V_C(t)$ demonstrates the under damped oscillations in RLC series circuit. Figure 3 displays $\varepsilon(t)$ and $V_C(t)$ simultaneously depicted from the oscilloscope. In equations (4) and (6), amplitude of $V_C(t)$ decays exponentially with a decay factor $e^{-\beta t}$ and oscillates sinusoidally with an oscillation factor $\cos(\omega t)$. That is, the voltage across the capacitor undergoes a damped harmonic oscillation in analogy with a mass–spring system moving in a viscous medium.

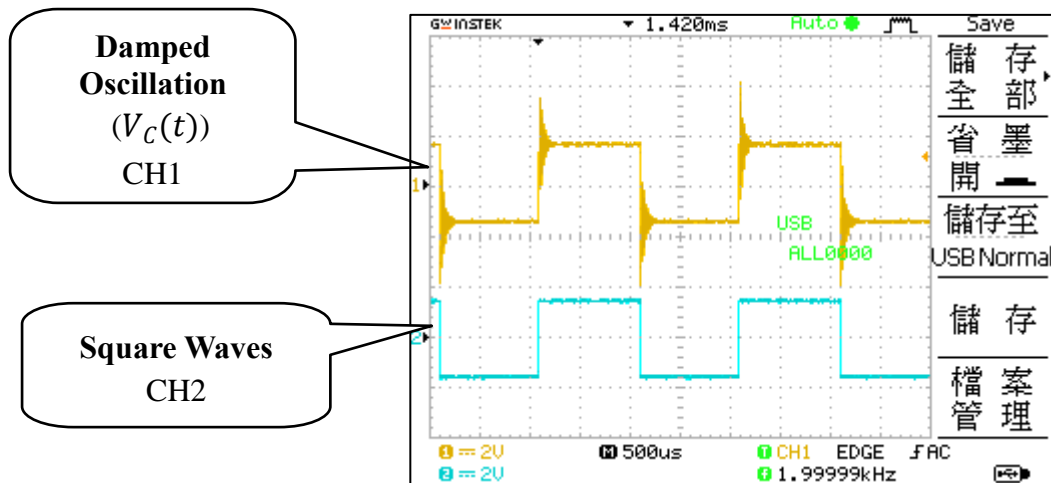

Figure 3. Damped oscillations (upper) and square waves (lower) in oscilloscope

From above, both β and angular frequency ω depend on resistance R , inductance L , and capacitance C in the RLC series circuit. The oscillation behaviors of the RLC circuit are shown as below :

1. When $\left(\frac{R}{2L}\right)^2 = \frac{1}{LC}$, then $\omega=0$, There is no oscillation and the voltage across the capacitor decays with time exponentially. It is called 「Critical Damping」.
2. When $\left(\frac{R}{2L}\right)^2 > \frac{1}{LC}$, then ω is an imaginary number. Hence, $\cos(\omega t) = \cosh(i\omega t)$ which is a hyperbolic cosine function. The voltage across the capacitor is a sum of two decaying exponentials with no oscillation. It is called 「Over Damping」.
3. When $\left(\frac{R}{2L}\right)^2 < \frac{1}{LC}$, then ω is a real number. The voltage across the capacitor is in damped oscillation that its amplitude decays with time exponentially. It is called 「Under Damping」.

Moreover, when $\left(\frac{R}{2L}\right)^2 \ll \frac{1}{LC}$, then the angular frequency of the oscillation would approach $\omega \sim \sqrt{\frac{1}{LC}} = \omega_0$, called (natural angular frequency).

In reverse charging process, $V_C(t)$ is plotted in figure 4 for these three cases.

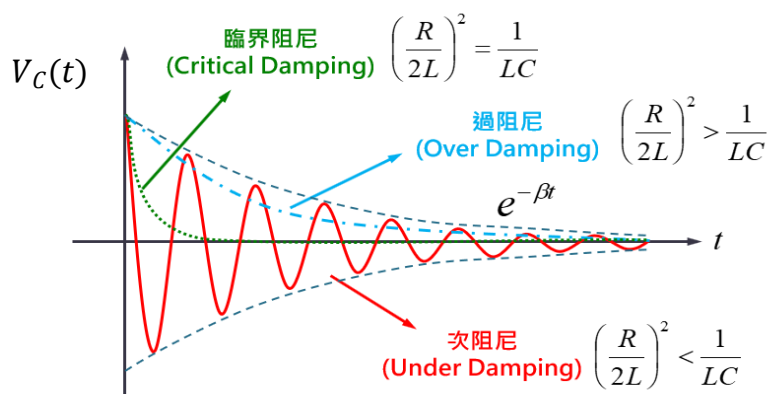

Figure 4. Oscillation phenomenon versus time

B. $\varepsilon(t)$ is a sinusoidal wave signal (AC)

The function generator generates a sinusoidal wave as shown in figure 5.

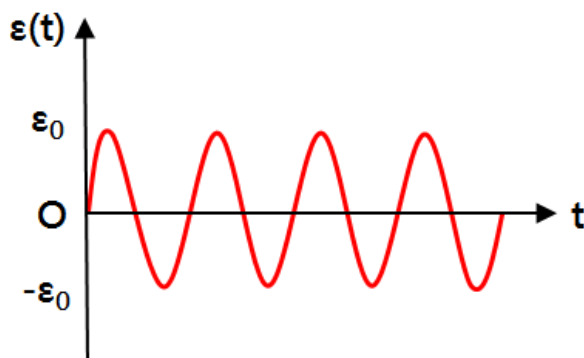

Figure 5. Sinusoidal wave of $\varepsilon(t)$.

Substitute $\varepsilon(t) = \varepsilon_0 \cos(\omega t)$ in equation (2) and the second differential equation can be represented as

$$\frac{d^2 V_C(t)}{dt^2} + \frac{R}{L} \frac{dV_C(t)}{dt} + \frac{1}{LC} V_C(t) = -\frac{\varepsilon_0}{LC} \cos(\omega t) \quad (7)$$

Obtain the solution $V_C(t)$ by solving equation (7). The voltage across resistor $V_R(t) = i(t)R = RC \frac{dV_C(t)}{dt}$ is as follows.

$$V_R(t) = \frac{\varepsilon_0 R}{\sqrt{R^2 + (\omega L - \frac{1}{\omega C})^2}} \cos(\omega t - \phi) \quad (8)$$

where phase difference $\phi = \tan^{-1} \left(\frac{\omega L - \frac{1}{\omega C}}{R} \right)$

and amplitude $|V_R(t)| = \frac{\varepsilon_0 R}{\sqrt{R^2 + (\omega L - \frac{1}{\omega C})^2}}$

Resonance and filter

From equation (8), $|V_R(t)|$ reaches a maximum, ε_0 , when angular frequency $\omega = \sqrt{\frac{1}{LC}}$. Such angular frequency is called resonance angular frequency ω_0 and this phenomenon is called **resonance**.

Figure 6 is a plot of $|V_R(t)|$ versus ω . Half-power points are present when $|V_R(t)| = \frac{\varepsilon_0}{\sqrt{2}}$ with corresponding angular frequencies, ω_l and ω_h (cutoff angular frequencies). The half-width of angular frequency is defined as $\Delta\omega = \omega_h - \omega_l$. In a RLC series circuit, $\Delta\omega = \frac{R}{L}$ is independent of C . It can be used for band-pass filtering. In application, resistance R and inductance L can be adjusted to result in the required bandwidth for passing or blocking signals close to the resonance frequency.

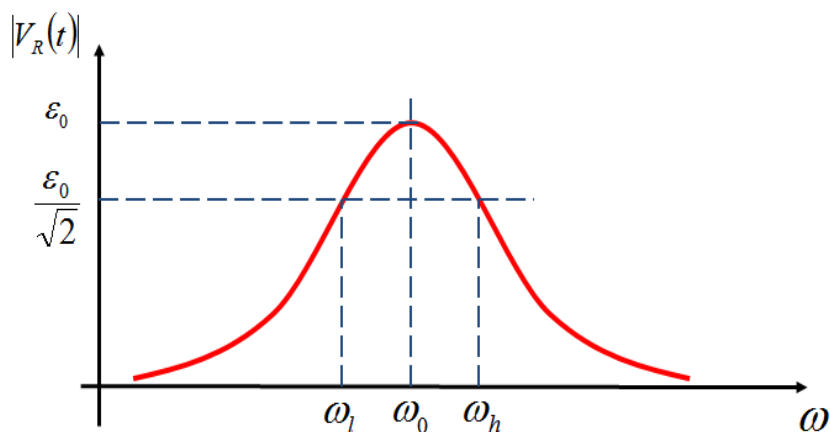

Figure 6. Sketch of amplitude $|V_R(t)|$ versus angular frequency.

Remarks :

1. Make sure the circuit is not a short circuit before powering instruments on.
2. Make sure that the switch of the resistor, the inductor, and the capacitors are off.

Procedure :

A. Under damping I -- $|V_C(t)|$

(Use CH1 of the oscilloscope to observe the voltage across the capacitor. Use BNC Tee adapter so that the output of the function generator can be the source of the circuit and simultaneously be the signal to CH2 of the oscilloscope.)

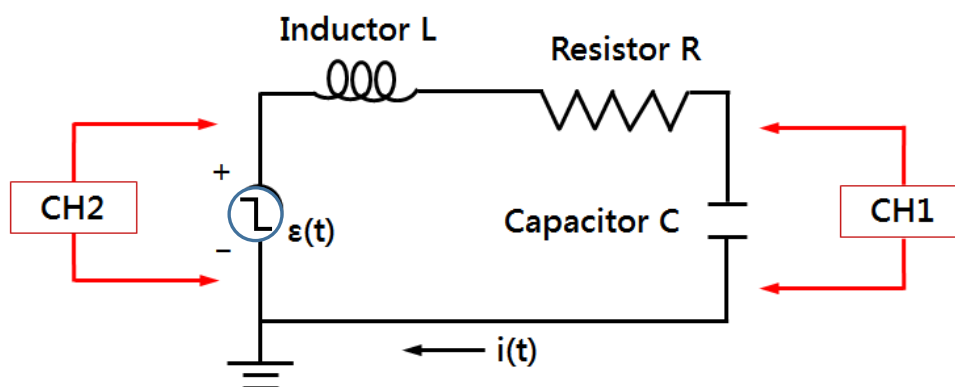

Figure 7. Circuit diagram of an RLC series circuit.

1. Connect all electronic elements as shown in figure 7.
2. Set resistance $R = 800 \Omega$, inductance $L = 10 \text{ mH}$, and capacitance $C = 100 \text{ pF}$.
3. Calculate the value of β .
4. Turn on the function generator. Set the generator to produce a square wave of frequency 500.0 Hz and amplitude $\epsilon_0 (=V_{\text{max}}) 1.00 \text{ V}$.

[Note] Peak to peak voltage $V_{\text{pp}} = 2.00 \text{ V}$ in CH2.

- Adjust 「VOLT/DIV」 and 「TIME/DIV」 knobs such that 2-3 periods of square wave(CH2) and underdamping waveforms (CH1) shown in the oscilloscope.
[Note] When no under damping shown, check the circuit.
- Adjust 「VOLT/DIV」 and 「TIME/DIV」 knobs again such that only one complete underdamping waveform shown in the oscilloscope. Record the peak value of $V_C(t)$ and corresponding time t .
- Plot $|V_C(t)|$ vs. t . Analyze data with the linear regression line to find β and calculate the percentage error.

B. Under damping II – Relation between angular frequency and capacitance

- Set resistance $R = 100 \Omega$ and inductance $L = 10 \text{ mH}$. Pick seven capacitors with capacitances in the region that $0.002 \mu\text{F} \leq C \leq 0.04 \mu\text{F}$.
- Following steps in part A, investigate the under damping wave for each case.
- Calculate angular frequency ω for each capacitance C .
- Use cursor method to obtain the periods of under damping oscillation T for circuits of different capacitors. Calculate angular frequency ω for each capacitance C .
- Plot ω^2 vs. $\frac{1}{C}$. Analyze data with the linear regression line to find $\frac{1}{L}$ and calculate the percentage error.

C. All kinds of Damping

Keep the inductance L , capacitance C constant. Change the resistance R , observe the under damping, critical damping and over damping oscillations.

D. Resonance

(Use CH1 of the oscilloscope to observe the voltage across the resistor. Use BNC T adapter so that the output of the function generator can be the source of the circuit and simultaneously be the signal to CH2 of the oscilloscope.)

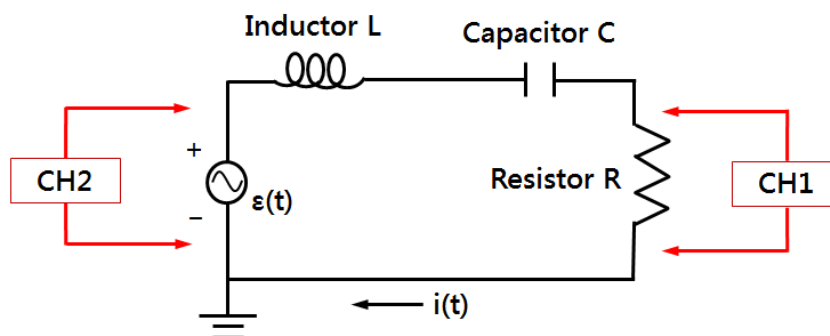

Figure 8. Circuit diagram of an RLC series circuit. (Force damping)

1. Set up the apparatus as shown in figure 8.
2. Set $R = 1 \text{ k}\Omega$, $L = 10 \text{ mH}$, and $C = 0.001 \text{ }\mu\text{F}$.
3. Calculate the expected resonance angular frequency ω_0 and resonance frequency f_0 .

$$\omega_0 = \sqrt{\frac{1}{LC}} \quad \& \quad f_0 = \frac{\omega_0}{2\pi}$$

4. Use the equation (8) to get the expected values of voltage amplitude across resistor $|V_R(t)|$ and phase difference ϕ .
5. Power on function generator. Set output is a sinusoidal wave with voltage amplitude ε_0 ($=V_{\text{max}}$) of 1.00 V.
[Note] in CH2, $V_{\text{pp}} = 2.00 \text{ V}$.
6. Set the frequency of the sinusoidal wave to be the expected resonance frequency f_0 .
[Note] It is expected that a maximum of $|V_R(t)|$ occur at f_0 . Hence, adjust slightly frequency around f_0 until $|V_R(t)|$ is a maximum and the frequency is the measured resonance frequency.
7. Set the oscilloscope to XY mode to get Lissajous curve.
8. Adjust slightly the frequency until we get the Lissajous pattern which frequency ratio is equal to 1 and the phase difference is zero.
[Note] When resonance occurs in a RLC circuit, there is no phase difference between $V_R(t)$ and output signal of function generator $\varepsilon(t)$.
9. Record the frequency displayed on the function generator (experimental value of resonance frequency). Set the oscilloscope to normal mode and record the voltage amplitude $|V_R(t)|$.
[Note] CH1 shows the voltage across the resistor.
10. Upon the measured resonance frequency, vary the frequency of the output sinusoidal signal of function generator with lower and higher frequencies and record corresponding voltage amplitude across the resistor, $|V_R(t)|$.
[Note] Angular frequency range should cover cutoff angular frequency ω_l and ω_h .
11. Plot $|V_R(t)|$ vs. ω .
[Note] Resonance angular frequency and cutoff angular frequency should be indicated in the plot.
12. Use interpolation method to obtain cutoff frequencies ω_l and ω_h .
13. Calculate half-width $\Delta\omega$ from this curve and compare with the theoretical value.
14. Keep the inductance L and the capacitance C constant. Vary the resistance R to 2 k Ω , and repeat the above steps.

Discussion hints :

1. In experiment of damped oscillation, a square pattern is observed in CH2 when only output of function generator is only connected to the oscilloscope. In contrast, what happened that the square wave is not perfect in the RLC circuit? Elaborate on it.
2. Given two conditions that $L = 10$ mH, $C = 0.01$ μ F and $L = 10$ mH, $C = 100$ pF, what value of R is required for observing the underdamped oscillation on the oscilloscope, respectively? Elaborate on it.
3. Give some applications of damped oscillation in daily life. Elaborate on it.
4. Prove the half-width of angular frequency $\Delta\omega = \frac{R}{L}$ for a RLC series circuit excited by a sinusoidal signal.
5. In experiment of resonance, how does the plot of the voltage amplitude of the resistors $|V_R(t)|$ versus the angular frequency ω evolve with different resistances R ? Elaborate on it.
6. In experiment of resonance, when the resistance R and the capacitance C are fixed constant with just changing the inductance L , how do the resonance frequency and half-width of frequency change with the inductance? Elaborate on it

Appendix I

Physical coefficients

Name	Symbol	Approximation	SI Unit
Avogadro's number	N_A	6.022×10^{23}	mol^{-1}
Boltzmann's constant	$k = R / N_A$	1.381×10^{-23}	J/K
Coulomb-law constant	$k (=1/4 \pi \epsilon_0)$	9.00×10^9	$\text{N} \cdot \text{m}^2 / \text{C}^2$
Electron mass	m_e	9.109×10^{-31}	kg
Elementary charge	e	1.602×10^{-19}	C
Permeability constant	μ_0	$4\pi \times 10^{-7}$	H/m
Permittivity constant	$\epsilon_0 (=1/\mu_0 c^2)$	8.854×10^{-12}	F/m
Planck's constant	h	6.626×10^{-34}	J·s
Speed of light in vacuum	c	3.00×10^8	m/s

Appendix II

TDS 2022 digital oscilloscope panel instruction :

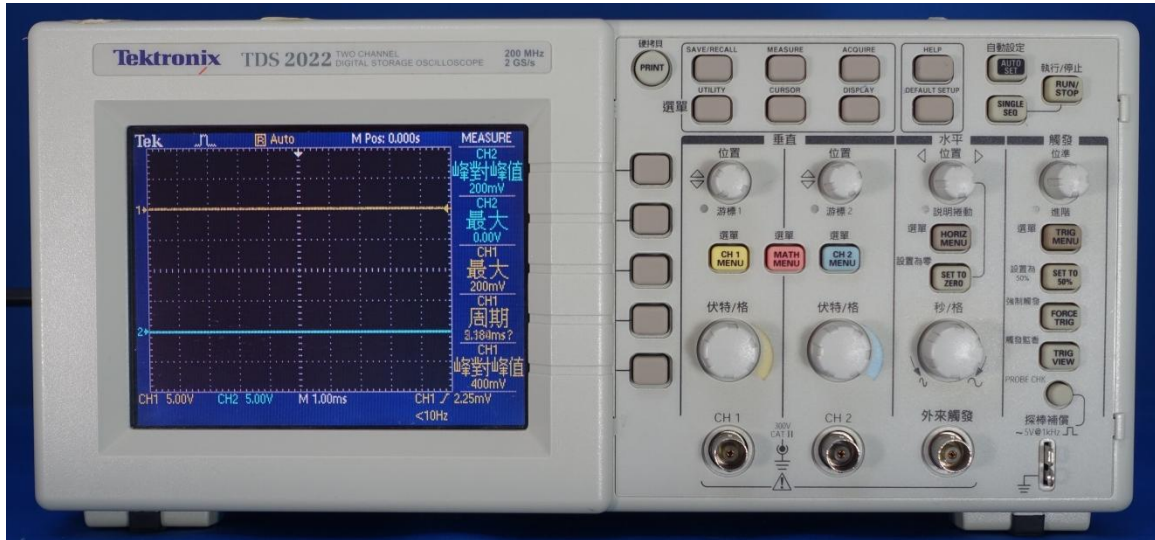

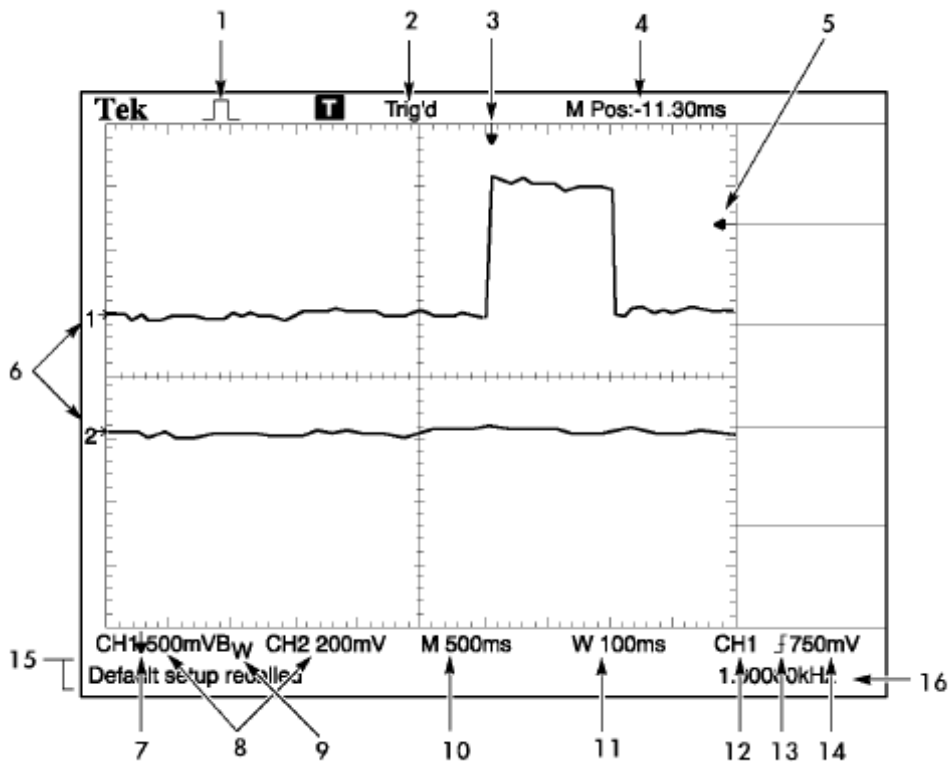

TDS 2022 digital oscilloscope panel

A. The front panel









1. Acquisition mode

-  Sample mode
-  Peak detect mode
-  Average mode

2. Trigger status indicates the following

<input type="checkbox"/> Armed.	The oscilloscope is acquiring pre-trigger data. All triggers are ignored in this state.
<input checked="" type="checkbox"/> Ready.	All pre-trigger data has been acquired and the oscilloscope is ready to accept a trigger.
<input checked="" type="checkbox"/> Trig'd.	The oscilloscope has seen a trigger and is acquiring the post-trigger data.
<input checked="" type="checkbox"/> Stop.	The oscilloscope has stopped acquiring waveform data.
<input checked="" type="checkbox"/> Acq. Complete	The oscilloscope has completed a Single Sequence acquisition.
<input checked="" type="checkbox"/> Auto.	The oscilloscope is in auto mode and is acquiring waveforms in the absence of triggers.
<input type="checkbox"/> Scan.	The oscilloscope is acquiring and displaying waveform data continuously in scan mode.

3. Marker shows horizontal trigger position. Turn the HORIZONTAL POSITION knob to adjust the position of the marker.
4. Readout shows the time at the center gratitude.
5. Marker shows Edge or Pulse Width trigger level.
6. On-screen markers show the ground reference points of the displayed waveforms.
7. An arrow icon indicates that the waveform is inverted.
8. Readouts show the vertical scale factors of the channels.
9. A "Bw icon" indicates that the channel is bandwidth limited Bw.
10. Readout shows main time base setting.
11. Readout shows window time base setting if it is in use.
12. Readout shows trigger source used for triggering.
13. Icon shows selected trigger type as follows

	Edge trigger for the rising edge.
	Edge trigger for the falling edge.
	Video trigger for line sync.
	Video trigger for field sync.
	Pulse Width trigger, positive polarity.
	Pulse Width trigger, negative polarity.

14. Readout shows Edge or Pulse Width trigger level.
15. Readout shows date and time.
16. Readout shows trigger frequency.

B. Vertical and horizontal controls

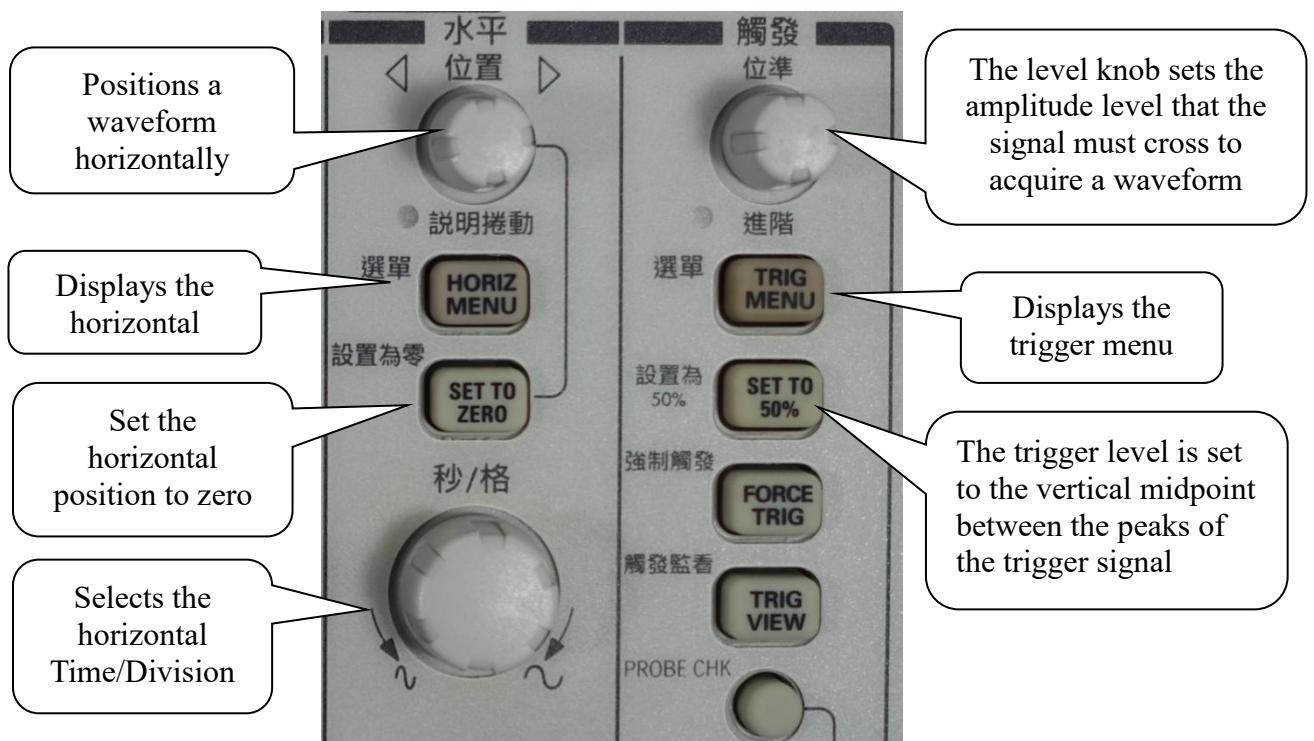
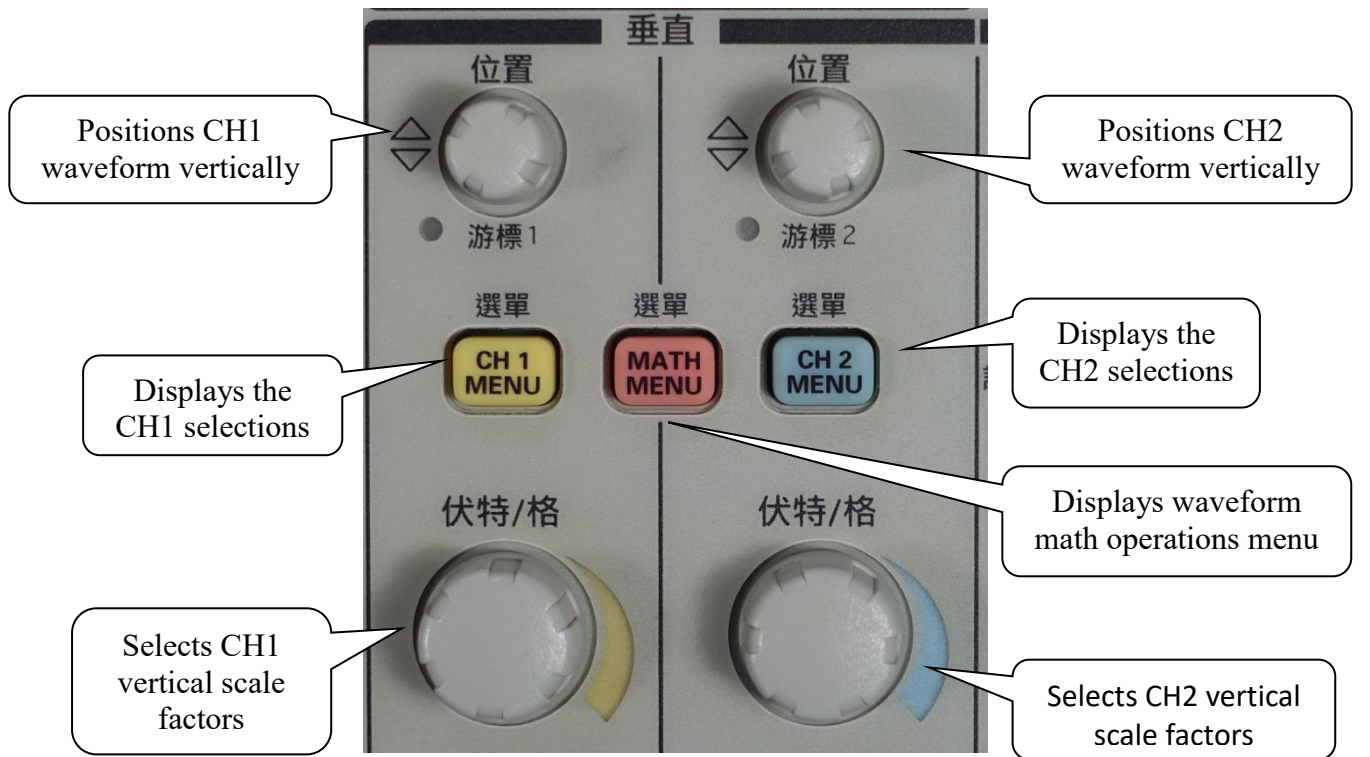

GDS 1152A digital oscilloscope panel instruction :

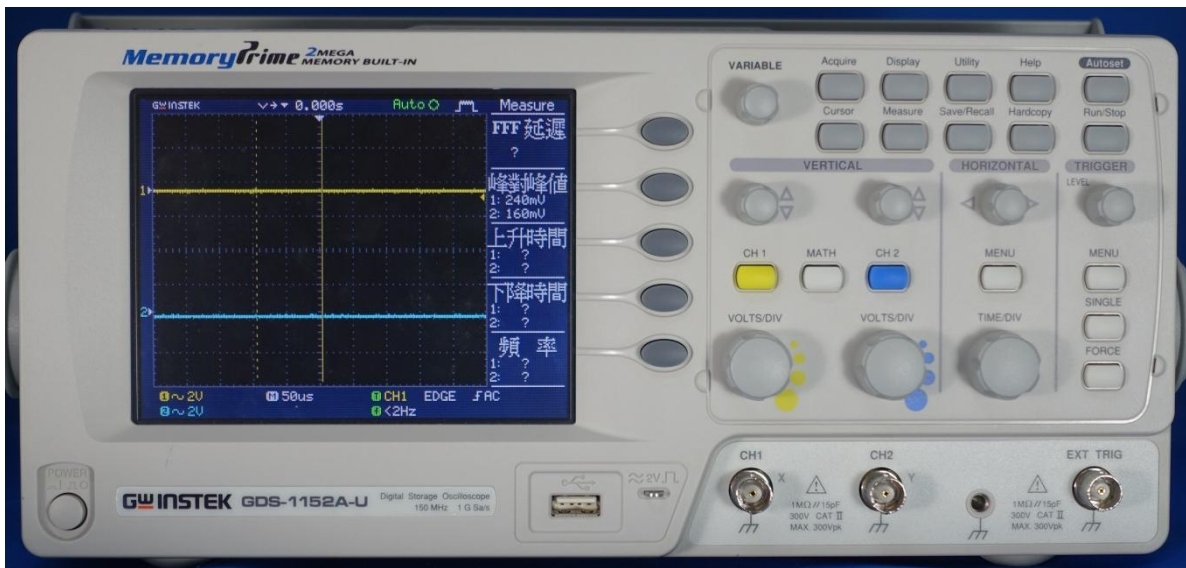

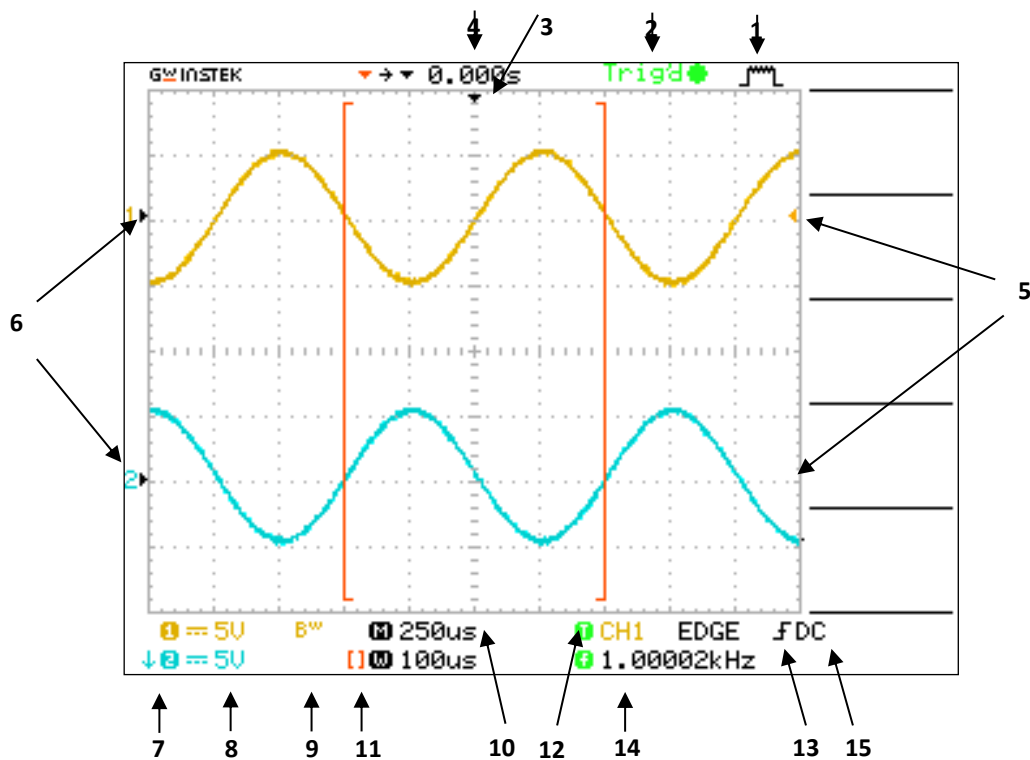

GDS 1152A digital oscilloscope panel

A. The front panel









1. Acquisition mode

-  Sample mode
-  Peak detect mode
-  Average mode

2. Trigger status indicates the following

<input type="checkbox"/> Armed.	The oscilloscope is acquiring pre-trigger data. All triggers are ignored in this state.
<input checked="" type="checkbox"/> Ready.	All pre-trigger data has been acquired and the oscilloscope is ready to accept a trigger.
<input checked="" type="checkbox"/> Trig'd.	The oscilloscope has seen a trigger and is acquiring the post-trigger data.
<input checked="" type="checkbox"/> Stop.	The oscilloscope has stopped acquiring waveform data.
<input checked="" type="checkbox"/> Acq. Complete	The oscilloscope has completed a Single Sequence acquisition.
<input checked="" type="checkbox"/> Auto.	The oscilloscope is in auto mode and is acquiring waveforms in the absence of triggers.
<input type="checkbox"/> Scan.	The oscilloscope is acquiring and displaying waveform data continuously in scan mode.

3. Marker shows horizontal trigger position. Turn the HORIZONTAL POSITION knob to adjust the position of the marker.
4. Readout shows the time at the center gratitude. The trigger time is zero.
5. Marker shows Edge or Pulse Width trigger level.
6. On-screen markers show the ground reference points of the displayed waveforms.
7. An arrow icon indicates that the waveform is inverted.
8. Readouts show CH1, Ch2 scale factors of the channels.
9. A "Bw icon" indicates that the channel is bandwidth limited Bw.
10. Readout shows main time base setting.
11. Readout shows window time base setting if it is in use.
12. Readout shows trigger source used for triggering.
13. Icon shows selected trigger type as follows

	Edge trigger for the rising edge.
	Edge trigger for the falling edge.
	Video trigger for line sync.
	Video trigger for field sync.
	Pulse Width trigger, positive polarity.
	Pulse Width trigger, negative polarity.

14. Readout shows Edge or Pulse Width trigger level.
15. Readout shows trigger frequency.

B. Vertical and horizontal controls

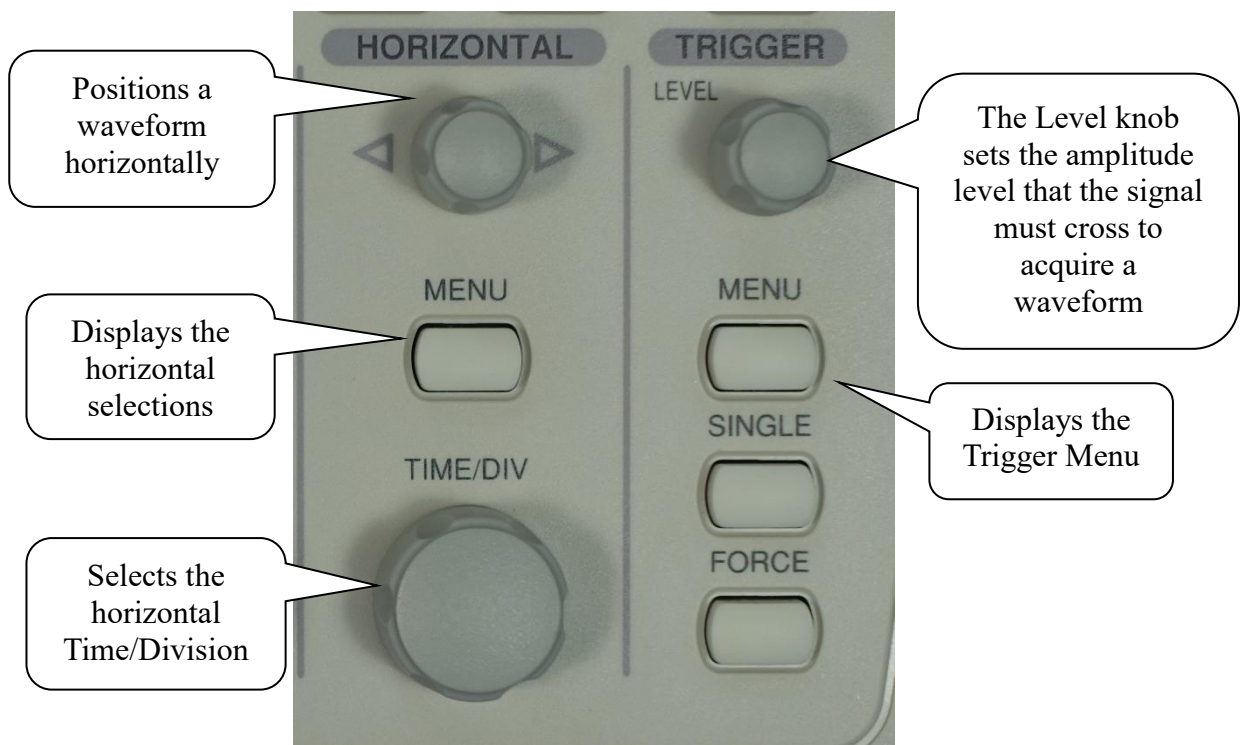
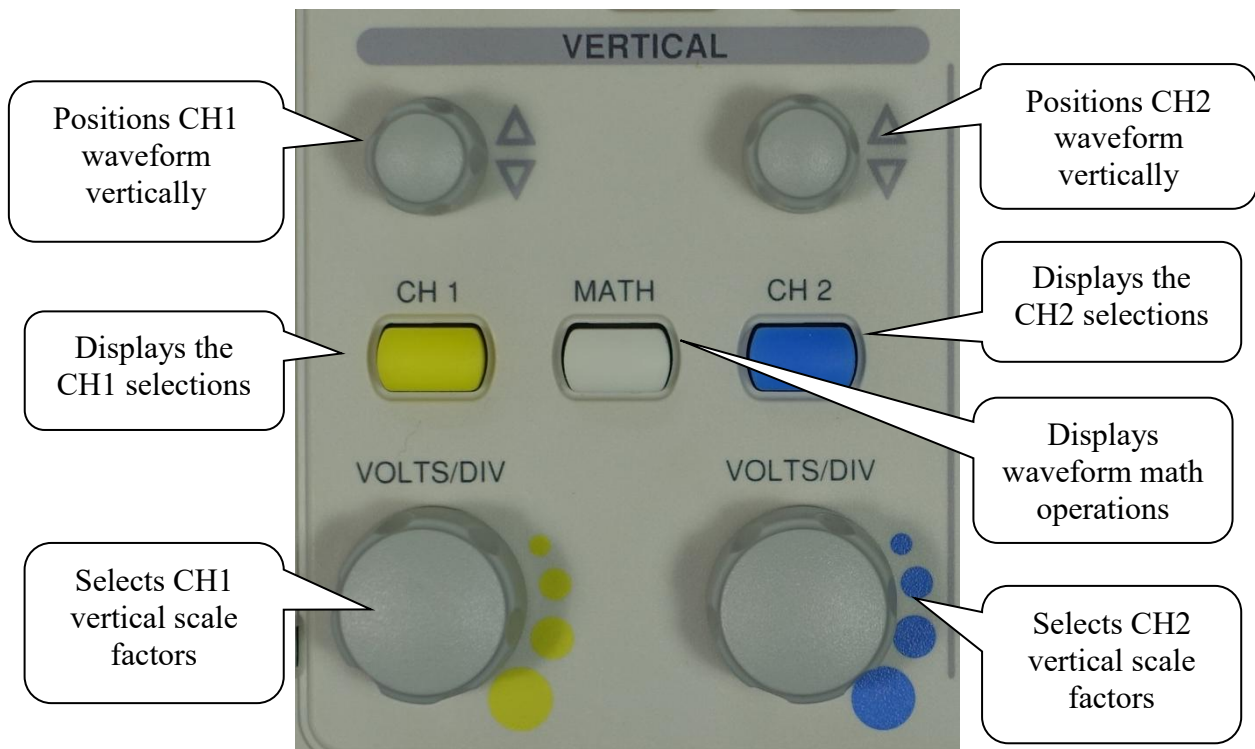

Appendix III

Function generator panel instruction :

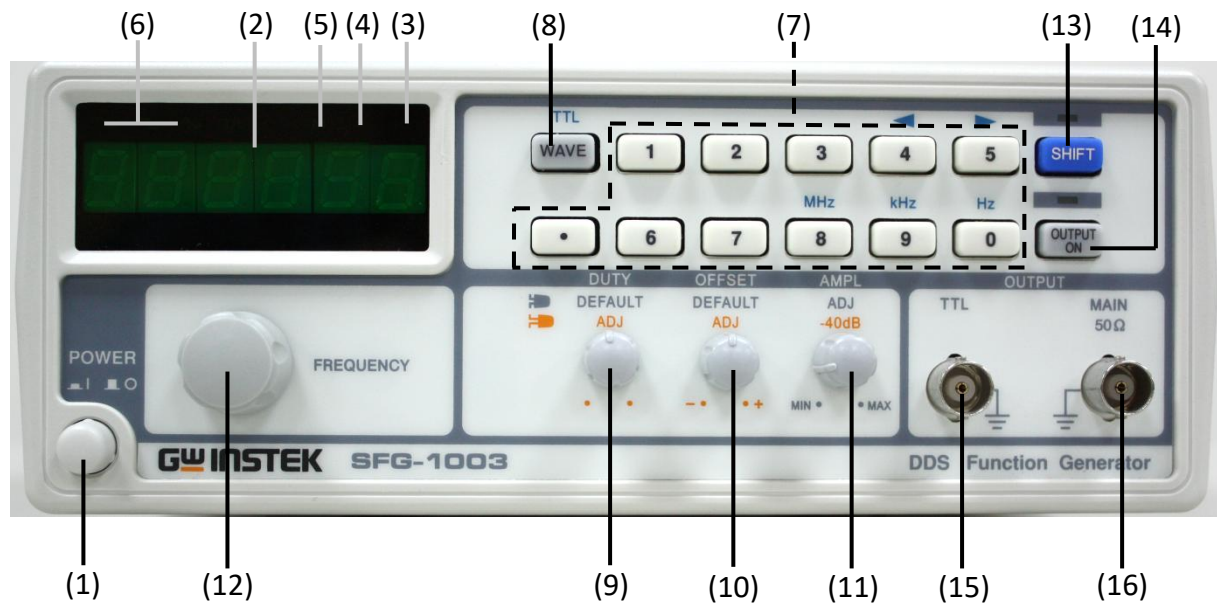

SFG-1003 Function Generator

1. Power switch
2. Main display
3. Hz indicator
4. kHz indicator
5. MHz indicator
6. Wave indicator
7. Entry keys
8. Waveform key
9. Duty control
10. Offset control (pull the knob)
11. Amplitude control
12. Frequency editing knob
13. Shift Key
14. Output on/off key
15. TTL (Transistor-Transistor Logic) output
16. Main output

Appendix IV

DC power supply panel instruction :

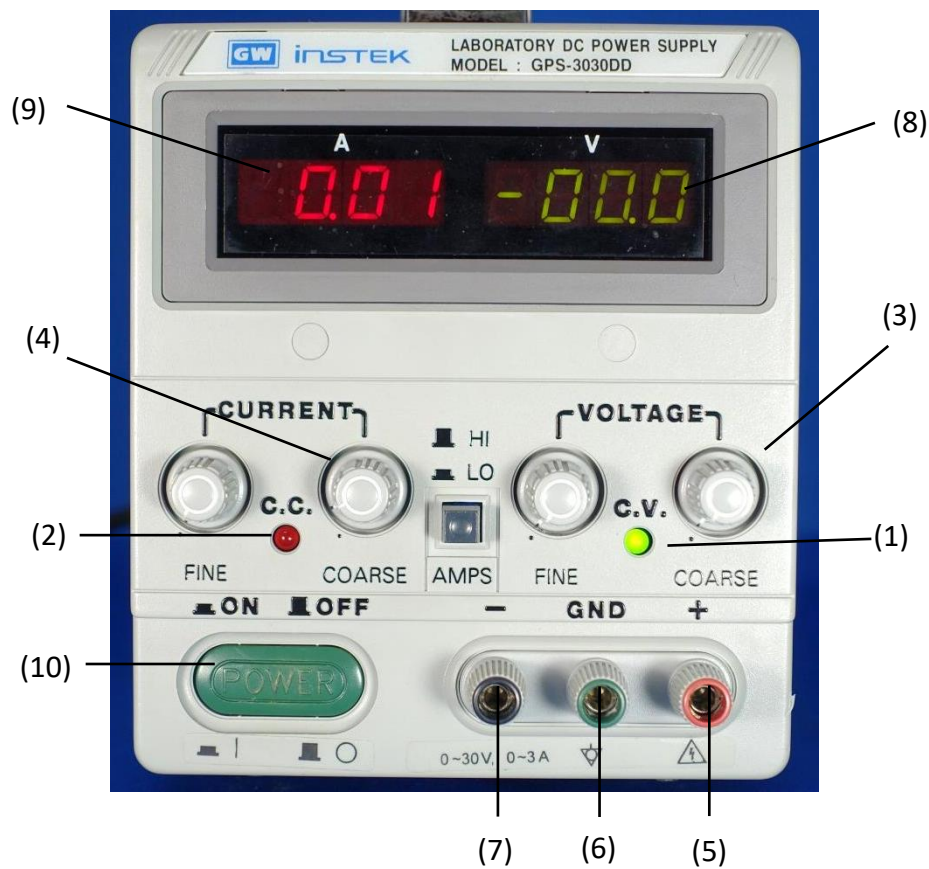

1. Constant voltage indicator
2. Constant current indicator
3. Coarse control of voltage
4. Coarse control of current
5. Output terminal (“positive”)
6. Output terminal (“ground”)
7. Output terminal (“negative”)
8. Voltage meter
9. Current meter
10. Power switch

Appendix V

GDM-8245 dual display digital multimeter :

Measurement items: DC Voltage/Current, AC Voltage/Current, resistance, etc. It can be regarded as a combination of current meter and voltage meter.

1. Press power button to warm up the instrument.
2. Press the function button (one of six on the bottom left corner of the front panel) to select desired function : direct voltage (DCV), alternating voltage (ACV), resistance (Ω), direct current (DCA), or alternating current (ACA).
3. Connect the test leads to input terminals : For measuring resistance or voltage, connect the test lead to the R/V and COM input terminals. For measuring current, Connect the test lead to the 2A ($I < 2\text{ A}$) or 20A ($I < 20\text{ A}$) and COM input terminals center right: COM, upper right: voltage or resistance (+) input, lower right: current (+) input, and center left : current (+) input **only for current less 2 A**.

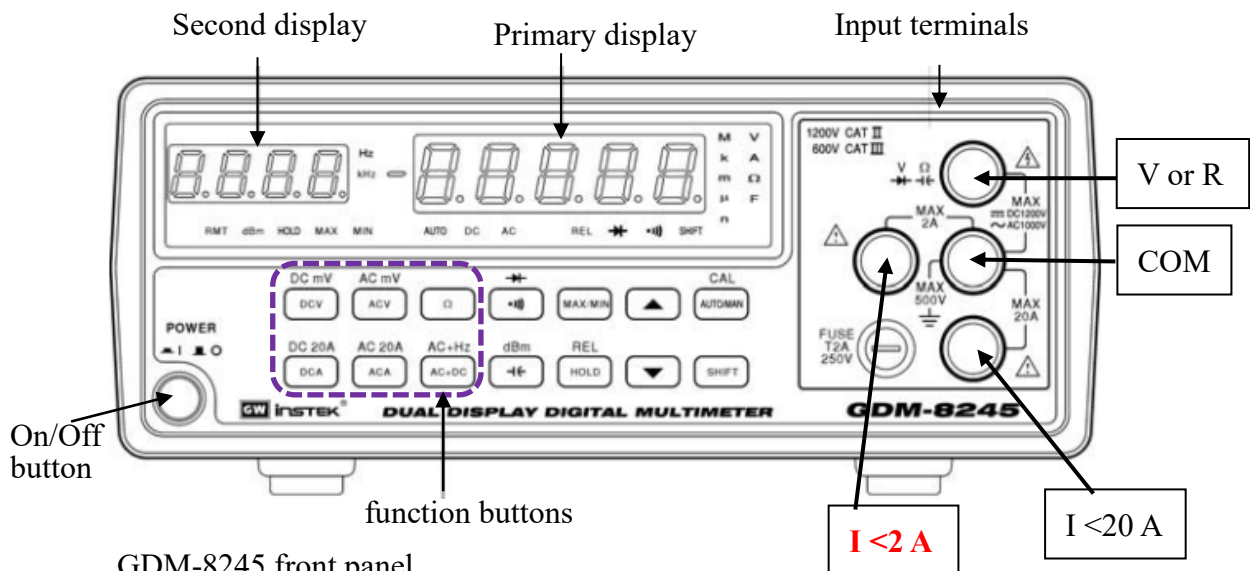

GDM-8245 front panel

The measured value is indicated in the primary display.

4. Press [AUTO/MAN] button to change manual or auto ranging. When in manual ranging, press 「▲」 or 「▼」 to the desired range.
(if you have no idea about the value of input. **always start at the highest range**).

Input overload protection:

Function	Range	Maximum allowable input
DCV	5 V ~ 1200 V	1200 V dc or $V_p=1200\text{ V ac}$
ACV (AC+DC)	5 V ~ 1000 V	1000 V rms
Ω		450 V dc or $V_p=450\text{ V ac}$
DCA, AC20A (AC+DC)	~20 A	No fuse
DCA, ACA (AC+DC)	50 μA ~ 2 A	fuse : 2 A/250 V

Appendix VI

Common electronic component symbols :

1. DC voltage : (battery)

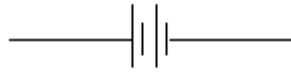

2. AC voltage : (function generator)



3. resistance : (fixed)



(tunable)

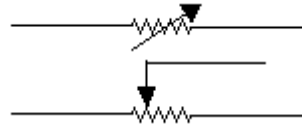

4. capacitor : (fixed)

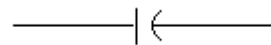
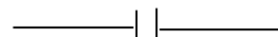

(tunable)

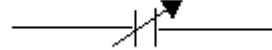

5. inductance : (fixed)



(tunable)

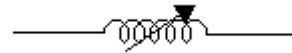

6. galvanometer :



7. current meter :



8. voltage meter :



9. ground :

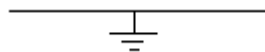

10. diode :

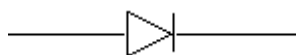

11. transistor :

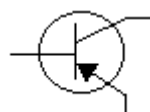

Appendix VII

Color Code :

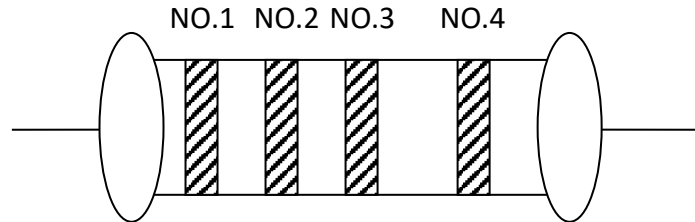

Color	No.1	No.2	No.3	No.4 (error)
Black	0	0	10^0	
Brown	1	1	10^1	$\pm 1\%$
Red	2	2	10^2	$\pm 2\%$
Orange	3	3	10^3	
Yellow	4	4	10^4	
Green	5	5	10^5	$\pm 0.5\%$
Blue	6	6	10^6	$\pm 0.25\%$
Purple	7	7	10^7	$\pm 0.1\%$
Grey	8	8	10^8	$\pm 0.05\%$
White	9	9	10^9	
Gold			10^{-1}	$\pm 5\%$
Silver			10^{-2}	$\pm 10\%$

EX :

(1) common resistance

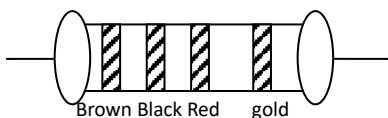

$$\Rightarrow 10 \times 10^2 \Omega \pm 5\% \Rightarrow 1 \text{ k}\Omega \pm 5\%$$

(2) accurate resistance

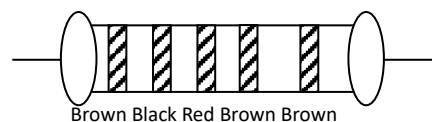

$$\Rightarrow 1102 \times 10^1 \Omega \pm 1\% \Rightarrow 1020 \Omega \pm 1\%$$

Appendix VIII

Solderless breadboard :

Because the solderless breadboard does not require soldering, it is reusable. This makes it easy to use for creating temporary prototypes and experimenting with circuit design. A variety of electronic systems may be prototyped by using breadboards, from small analog and digital circuits to complete central processing units.

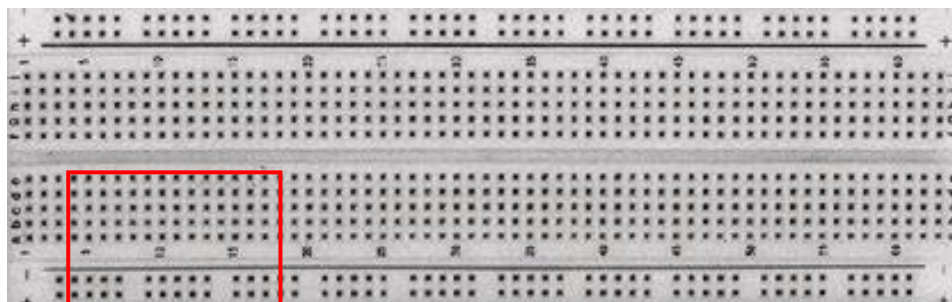

Figure 1. breadboard

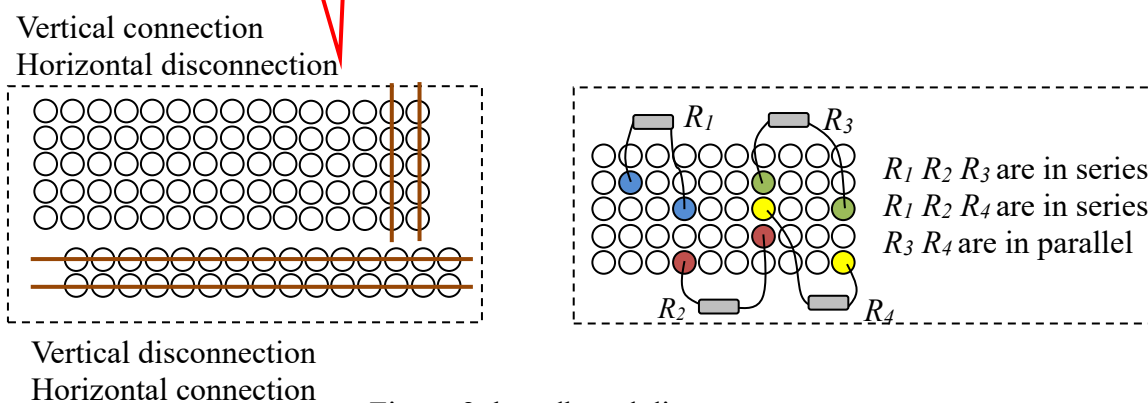

Figure 2. breadboard diagram